



GarrettCom™
Ethernet at Its Best™

Magnum 6K8-Series Industrial Field Switch



Hardware Installation and User Guide

Magnum™ 6K8-Series

Industrial Field Switch

Hardware

Installation and User Guide

Part #: 84-00160 (Rev. A)

Trademarks

Ethernet is a trademark of Xerox Corporation

NEBS is a trademark of Telcordia Technologies

UL is a registered trademark of Underwriters Laboratories

GarrettCom, Magnum and **Personal Switch** are trademarks and **Personal Hub** is a registered trademark of GarrettCom, Inc.

Important: The Magnum 6K8-Series Industrial Field Switch contains no user serviceable parts. Attempted service by unauthorized personnel shall render all warranties null and void. If problems are experienced with Magnum 6K8-Series Switch products, consult Section 6, Troubleshooting, of this User Guide.

Copyright © 2006 GarrettCom, Inc. All rights reserved. No part of this publication may be reproduced without prior written permission from GarrettCom, Inc.

Printed in the United States of America.

Contacting GarrettCom, Inc

Please use the mailing address, phone and fax numbers and email address listed below:

GarrettCom, Inc.

47823 Westinghouse Dr.

Fremont, CA 94539-7437

Phone (510) 438-9071

Fax (510) 438-9072

Website: <http://www.GarrettCom.com>

email support@garrettcom.com

Federal Communications Commission
Radio Frequency Interference Statement

Radio Frequency Interference Statement

This equipment generates, uses and can radiate frequency energy and if not installed and used properly, that is in strict accordance with the manufacturer's instructions, may cause interference to radio communication. It has been tested and found to comply with the limits for a Class A computing device in accordance with the specifications in Subpart J of Part 15 of FCC rules, which are designed to provide reasonable protection against such interference when operated in a commercial environment. Operation of this equipment in a residential area is likely to cause interference, in which case the user, at his own expense, will be required to take whatever measures may be required to correct the interference.

Canadian Emission

This Class A digital apparatus meets all requirements of the Canadian Interference-Causing Equipment Regulations.

Cet appareil respecte toutes les exigences du Règlement sur le matériel du Canada. Cet appareil est Classe A..

Table of Contents	Page
1.0 SPECIFICATIONS	2
1.1 Technical Specifications	2
1.2 Ordering Information	5
2.0 Introduction.....	7
2.1 Inspecting the Package and Product	7
2.2 Product Description - Magnum 6K8-Series (6K8)	8
2.2.1a Magnum 6K8-Series, Industrial Field Switch.....	9
2.2.2 Eight-port SFF fiber modules 100Mb fiber	11
2.2.3 Eight-Port Copper Module, 6K8-RJ45	12
2.2.4 Six-Port “4 + 2”Combo Modules, fiber 100Mb ST or SC.....	12
2.2.5 Four-Port 10 Mb and 100Mb mm Fiber ST Modules	13
2.2.6 Gigabit (1000Mbps) port modules.....	14
2.2.7 Packet Prioritization, 802.1p QOS.....	14
2.2.8 Frame Buffering and Flow Control.....	15
2.2.9 Managed Network Software for Magnum 6K8-Series	16
2.3 Features and Benefits	17
2.3 Features and Benefits	17
2.4 Applications	18
3.0 Installation.....	22
3.1 Locating Magnum 6K8-Series Switches.....	22
3.2 Connecting Ethernet Media	23
3.2.1 Connecting Fiber Optic ST-type, “twist-lock”.....	23
3.2.2 Connecting Fiber Optic SC-type, "Snap-In"	24
3.2.3 Connecting Single-Mode Fiber Optic	24
3.2.4 Connecting Twisted Pair Unshielded or Shielded	24
3.2.5 Connecting Twisted Pair Unshielded or Shielded	25
3.2.6 Connecting Gigabit Media Using GBICs	25
3.3 DIN-Rail Mounting.....	25
3.3.1 Installing DIN-RAIL variable brackets on Magnum 6K8	27
3.3.2 Mounting Dimensions for 6K8 with metal brackets	29
3.4 Powering the Magnum 6K8-Series Industrial Field Switch	30
3.5 Alarm Contacts for monitoring internal power, and Software Traps....	31
3.6 6K8-Series Port Module (6KPMV) Installation	31
3.6.1 Preparation for Installing and Removing 6KPMVs from 6K8’s	32
3.6.2 Installing 6KPM Cards in the Magnum 6K8-Series	34
3.6.3 Removing 6KPM Cards	37
3.7 Connecting a Management Console Terminal to Magnum 6K8.....	38
3.7.1 RS-232 (DB-9) Console Com port (Serial port) pin assignments.39	
4.0 OPERATION	40
4.1 Switching Functionality	40
4.2 Dual LEDs Status on TOP and Front of the 6K8-Series unit	41
4.3 Auto-Cross(MDIX) and Auto-negotiation, for RJ-45 ports.....	41

- 4.4 Flow-control, IEEE 802.3x Standard 43
- 4.5 Power Budget Calculations for Magnum 6K8-with Fiber Media 43
- 5.0 Introduction - Magnum 6K8 Industrial Field Switch Port Modules** **45**
- 5.1 Inspecting the Package and Product 45
- 5.2 6KPMV Module Description 45
 - 5.2.1 6KP6-RJMST, FX-ST “twist lock” Combo Module 46
 - 5.2.1a 6KP6-RJ10ST, mm FX-ST “twist lock” Combo Module 46
 - 5.2.1b 6KP4-F10ST, multi-mode FX-ST “twist lock” Module 47
 - 5.2.1c 6KP4-FLSTFX, multi-mode FX-ST “twist lock” Module 47
 - 5.2.2 6KP6-RJMSC multi-mode FX-SC “snap-in” Fiber connector 48
 - 5.2.3 6KP6-RJSSC single-mode FX-SC-type, “snap-in” connector... 48
 - 5.2.4 6KP6-RJSSCL single-mode FX-SC-type, “snap-in” connector 49
 - 5.2.4a 6KP6-RJ10ST multi-mode FL-ST-type, “twist-lock” connector 49
 - 5.2.5 6KP8-MTRJ, small-Form-factor 50
 - 5.2.5a 6KP6-MT10ST, MTRJ Small-Form-Factor ST-Fiber port 50
 - 5.2.6 6KP8-45MT, MTRJ Small-Form-Factor 51
 - 5.2.7 6KP8-MLC, Small-Form Factor 51
 - 5.2.8 6KP8-45LC, LC small-form factor 52
 - 5.2.9 6KP8-RJ45 (Twisted Pair), 10/100Mb 8-Port 52
 - 5.2.10 6KP8-45-2MT, multi-mode FX , MTRJ Small-Form-Factor 53
 - 5.2.10a 6KP8-45-2LC, single-mode FX , LC Small-Form-Factor 53
 - 5.2.11 GBIC-SXSC Gigabit fiber(1000Mb)multi-mode SC Connector 54
 - 5.2.11a GBIC-LXSC Gigabit fiber multi-mode SC Connector 55
- 6.0 TROUBLESHOOTING 56**
- 6.1 Before Calling for Assistance 56
- 6.2 When Calling for Assistance 57
- 6.3 Return Material Authorization (RMA) Procedure 57
- 6.4 Shipping and Packaging Information 58
- APPENDIX A: WARRANTY INFORMATION 58**
- APPENDIX B : Internal DC Power Supply Options 58**
- APPENDIX C: Internal DC Dual-Source Power Option 61**

Revisions

03/06: Minor update on

10/05 : Initial Release, Rev A

09/05 : Draft of Initial Release, Rev A

THE MAGNUM LINE

Ethernet connectivity products

"Designed and Manufactured in the USA"

Overview

GarrettCom, Inc. offers the premium-quality Magnum™ line of Ethernet LAN connectivity products with industry-standard functionality and built-in fiber configurability. Magnum products are designed for use in demanding Carrier Class, Industrial Grade and OEM applications where reliability is a primary consideration.

6K-Series Managed Fiber Switches, MODULAR- Gigabit, 100 and 10 Mbps, fiber and copper ports, mix-and match. Features SFF fiber and DC power in 1U units.

Edge SwitchEs, Economical 6 port 10/100 and a combo of fiber+copper, provide an effective solution for Industrial and outdoor environment.

POE POWER SOURCE SWITCH, 4 10/100 Power source switch to provide power, data, and voice through RJ-45 ports.

Converter and convenient switches, 4 port 10/100 compact & economical switches and 3-port (2 10/100 and one fiber 10 or 100Mbps) converter switches for temperature uncontrolled locations.

4K-Series Switches, 100 and 10 Mbps, copper ports with optional fiber port, with auto-negotiating full switching performance.

Quad-Series Fiber Switches, MODULAR- 100 & 10Mbps, fiber and copper ports, mixed-speed and mixed-media types, full switching performance.

“Outdoor” Ethernet Switch, for temperature uncontrolled locations 6 10/100 and 2 100Mb fiber ports, can be connected in strings

Mixed-Media Fiber Hub, 16-port Stackable, 10/100 auto-sensing

Dual Speed 8-port and 16-port Stackables, 10/100 auto-sensing

Stackable Hubs, SNMP Optional

10Mb series(12/24 ports RJ-45), w/ optional port modules

Personal Switches, 10/100Mb

8 port dual speed, Auto-negotiable with fiber option

Personal Hubs, 100Mb or 10/100Mb

8-port, with two switched ports (1 fiber built in)

Personal Hubs, 10Mb series

8-port + AUI, stackable to 5 high, + optional BNC of fiber port

8 or 9-port and 4 or 5-Port Personal Hubs, w/ man. up-link sw.

Media Converters, 10Mb and 100Mb series

All media combinations, incl. fiber ST, SC, mm., single mode

The “X-line” of configurable MiXed Media products:

Stackable Concentrators, SNMP optional, 13-Ports

Mini-Concentrators, 7 Ports, Repeaters, 2-Ports

Repeater Port Modules (RPMs), 6 types for Ethernet media

Bridge Port Modules (BPMs), 4 types, for segment isolation

Transceivers, 10Mb series Mini-Transceivers and Coax Models

Mar., 06

1.0 SPECIFICATIONS

1.1 Technical Specifications

Performance

Filtering / Forwarding Rate:

Ethernet(10Mb):14,880 pps

Fast Ethernet(100Mb): 148,800 pps

Gigabit Ethernet(1000Mb): 1, 488,000 pps

Switching Processing Type: Store and Forward with IEEE 802.3x full-duplex flow -control, non-blocking

Data Rate: 10Mbps,100Mbps and 1000Mbps

Address Table Capacity: 4K node, self-learning with address aging

Packet buffer size : 240KB for 10/100 and 120KB for 1000Mb

Latency: 5 μ s + packet time (100 to 100Mbps)

15 μ s + packet time (10 to 10 Mbps, and 10 to 100Mbps)

Network Standards and Compliance, hardware

Ethernet V1.0/V2.0 IEEE 802.3: 10BASE-T,

IEEE 802.3u: 100Base-TX, 100BASE-FX

IEEE 802.3z: 1000BASE-TX Ethernet (Auto-Negotiation)

IEEE 802.3ab: 1000BASE-TX Ethernet

IEEE 802.1p: Priority protocol

IEEE 802.1d: Spanning tree protocol

IEEE 802.1q: VLAN Tagging

IEEE 802.3x: Flow Control

Maximum 10 Mbps Ethernet Segment Lengths

Unshielded twisted pair	- 100 m (328 ft)
Shielded twisted pair	- 150 m (492 ft)
10BASE-FL multi-mode fiber optic	- 2 km (6,562 ft)
10BASE-FL single-mode fiber optic	- 10 km (32,810 ft)

Maximum Standard Fast Ethernet Segment Lengths:

10BASE-T (CAT 3, 4, 5 UTP)	- 100 m (328 ft)
100BASE-TX (CAT 5 UTP)	- 100 m (328 ft)
Shielded twisted pair	- 150 m (492 ft)
100BASE-FX, half-duplex, multi-mode	- 412 m (1350 ft)
100BASE-FX, full-duplex, multi-mode	- 2.0 km (6,562 ft)
100BASE-FX, half-duplex, single-mode	- 412 m (1350 ft)
100BASE-FX, full-duplex, single-mode	- 20.0 km (66K8-Series ft)
100BASE-FX, full-duplex, Long Reach	- 40.0 km (122K ft)

Maximum Standard Gigabit Ethernet Segment Lengths:

1000BASE-T (CAT5e or higher is recommended)	- 100 m (328 ft)
1000BASE-SX, full-duplex, multi-mode(62.5 μ m cable)	- 220m
1000BASE-SX, full-duplex, multi-mode(50 μ m cable)	- 550m
1000BASE-LX, full-duplex, single-mode(62.5 μ m cable)	- 5Km

Fiber Multi-mode connector types supported:

Fiber Port, ST-type (twist-lock):Fiber multi-mode, 10Mb 10BASE-FL

Fiber Port, MTRJ-type (plug-in):SFF Fiber multi-mode100BASE-FX

Fiber Port, SC-type (snap-in):Fiber optic multi-mode, 100BASE-FX

Fiber Port, ST-type (twist-lock): Fiber optic m.-mode, 100BASE-FX

Fiber Port, 1000BASE-FX, GBIC modules

Fiber Single-mode connector types:

Fiber Port, SC-type: Fiber optic single-mode, 100BASE-FX
Fiber Port, LC-type: Fiber optic SFF single-mode, 100BASE-FX
Fiber Port, 100BASE-FX, GBIC modules

LEDs: Per Port (one set at the port, one set on rear top)

LK: Steady ON when media link is operational

ACT: ON with receiver port activity

FDX/HDX: ON = Full-Duplex Mode
OFF = Half-Duplex Mode

100/10: ON = 100Mbps speed
OFF = 10 Mbps

Operating Environment

Ambient Temperature:

-40° to 140° F (-40° to 60°C) for UL60950 and Component Parts rating

-60° to 205° F (-50° to 95°C) for IEC 60068 Type Test short term rating

Storage Temperature: -60° to 210°F (-50° to 100°C)

Ambient Relative Humidity: 5% to 95% (non-condensing)

Altitude: -200 to 13,000 ft. (-60 to 4000m)

Conformal Coating (humidity protection) option: Request quote

Alarm Relay Contacts

One NC indicating internal power, one NC software controllable

Packaging

Enclosure: Rugged High strength sheet metal.

Dimensions: 9.8 in. H x 5.90 in. W x 3.70 in. D

24.9 cm H x 15.0 cm W x 9.4 cm D

Cooling method: Convection, fully –enclosed elongated dual-cavity case
used as heat-sink. designed for **vertical mounting**, no fans

Weight: 2.1 lbs. (0.95 kg)

Management Console connector

DB-9 for RS-232 “null-modem” cable (sometimes called an X-modem cable)

Power Supply (Internal)

AC Power Connector: IEC-type, male recessed at rear of chassis,

Input Voltage: 100 to 240 VAC (auto-ranging)

Input Frequency: 47 to 63 Hz (auto-ranging)

Power Consumption:

25 watts typical (for a fully loaded fiber model)

15 watts typical (for a 8-port copper only model)

DC Power Supply (Options)

-48VDC Power Input Voltage : -36 to -70 VDC

24VDC Power Input Voltage : 18 to 36VDC

125VDC Power Input Voltage : 88 to 300VDC

5VDC Power Input Voltage : (+) or (-) 5%

Std. Terminal Block : “-, GND, +”

Power Consumption: same as for AC models, see above

For DC internal power supplies at -48VDC, 24VDC and 125VDC, including Dual Source options (for continuity of operation when either of the DC input sources are interrupted), see Appendices B and C.

Per-port MDI or MDIX on RJ-45

The copper daughter board has MDI-MDIX Auto-crossover on all the RJ-45 ports., and eliminate the use of cross-over cable between the devices. Also port-specific user settings (such as FDX or HDX, copper 10/100 speed) can be fixed using software commands.

Mountings:

Vertical mounting only Suitable for wall or DIN-Rail mounting

Agency Approvals**Magnum 6K8**

UL listed (UL60950), cU, CE

Emissions meet FCC Part 15 Class A

IEEE P1613 Environmental Standard for Electric Power Substations

IEEE 61850 EMC and Operating Conditions, class C for Electric Power Substations

NEMA TS-2 and TEES for traffic control equipment

Note: These products are tested and approved under IEC61850 for use in Class C sheltered locations where neither temperature nor humidity are controlled. The equipment needs to be protected against solar radiation, rainfall, other precipitations and wind. UL has not approved these products for Annex-T outdoor use.

Warranty: Three years, per UL 60950 temperature rating Made in USA

Email sales@GarrettCom.com for details.

1.2 Ordering Information**Magnum Industrial Field Switch (8 ports max)****MODEL DESCRIPTION**

Magnum 6K8 -Managed Industrial Field Switch, base unit for vertical mounting. Worldwide AC power. May be configured with a selection of 10/100/1000 fiber and copper port connector types, 8 total ports max. for 10/100Mbps or 2 ports maxm for Gigabit ports. Two metal brackets for vertical wall or panel mounting. Wire speed filtering and forwarding across all ports, 802.3x flow control, 802.1p priority packet processing, self-learning 4K-node address table, large 240KB packet buffers for 10/100 and 120KB for 1000Mb. For licensed managed networks software (MNS-6K and S-ring), See separate data sheets.

Magnum 6K8 -24VDC: Same as 6K8 except the power input is 24VDC

Magnum 6K8 -5VDC: Same as 6K8 except the power input is regulated 5VDC & fused

Magnum 6K8-48VDC: Same as 6K8 except the power input is -48VDC

Magnum 6K8-125VDC: Same as 6K8 except the power input is 125VDC

Configuration Options:

Each Magnum 6K8 base unit has one port module slot which can be equipped with one of the following single or multi-mode fiber, copper, 1000, 100 or 10Mbps modules.

Magnum 6K8 Port Modules

6KP8V-RJ45	TP Module, with 8x10/100Mbps auto-negotiating RJ-45 ports
6KP8V-MTRJ	SFF Fiber module, with 8x100Mb mm FX MT-RJ connectors
6KP8V-MLC	SFF Fiber module, with 8x100Mbps mm FX LC connectors
6KP8V-SLC	SFF Fiber module, with 8x100Mbps single-mode FX LC connectors
6KP4V-FXSC	“2+2” 100Mb Fiber module, with 4x100Mb 2km FX SC connectors
6KP4V-FXST	“2+2” 100Mb Fiber module, with 4x100Mb 2km FX ST connectors
6KP4V-F10ST	“2+2” 10Mb Fiber module, with 4x10Mb 2km FL ST connectors
6KP4V-FLSTFX	“2+2” ST Fiber module, with 2x100Mb & 2x10Mb ports, 2km
6KP8V-45-2MT	“6+2” module, with 6xRJ-45 ports and 2x100Mb 2km FX MTRJ
6KP8V-45-2SLC	“6+2” module, with 6xRJ-45 ports and 2x100Mb s.m 15km FX LC
6KP8V-45MT	“4+4” module, with 4xRJ-45 ports and 4x2km mm FX MTRJ
6KP8V-45MLC	“4+4” module, with 4xRJ-45 ports and 4x2km mm LC connectors
6KP8V-45SLC	“4+4” module, with 4xRJ-45 ports and 4x2km single mode LC
6KP6V-RJMST	“4+2” module, with 4xRJ-45 ports and 2x2km mm FX SC
6KP6V-RJMSC	“4+2” module, with 4xRJ-45 ports and 2x2km mm FX ST
6KP6V-RJSSC	“4+2” module, with 4xRJ-45 ports and 2x20km single.mode FX SC
6KP6V-RJSSCL	“4+2” module, with 4xRJ-45 ports and 2x40km single mode FX SC
6KP6V-MT10ST	“4+2” module, with 4xMTRJports and 2x10Mb 2km FL ST
6KP6V-RJ10ST	“4+2” module, with 4xRJ-45 ports and 2x10Mb 2km FL ST

- 6KP5V-G4RJ** “G+4” module, with one GBIC receptacle for one user selectable GBIC transceiver (see below) with 4 fixed 10/100 RJ-45 ports.
- 6KP3V-G2SC** “G+2” module, with one GBIC receptacle for one user selectable GBIC transceiver (see below) and 2 100Mb 2km FX SC fiber ports.
- GBPMV-20TX** Two-port Gigabit module for 6K8-Series Switches, with two GBIC receptacles for user selectable GBIC transceivers (see below).
- GBPMV-COTX** One slot Gigabit module for 6K8-Series Switches, with one GBIC receptacle for a user selectable GBIC transceiver module (see below).

GBIC(1000Mb) Transceiver options for Mangum 6K8-Series

- GBIC-SXSC** One 1000BASE-SX port with 850nm multi mode SC fiber connector
- GBIC-LXSC10** One 1000BASE- LX/LH port with 1310nm single mode SC(10km) fiber connector
- GBIC-LXSC25** One 1000BASE- LX/LH port with 1310nm single mode SC(25km) fiber connector
- GBIC-ZXSC40** One 1000BASE-ZX port with 1550nm, single mode SC(40km) fiber connector
- GBIC-ZXSC70** One 1000BASE-ZX port with 1550nm, single mode SC(70km) fiber connector
- GBIC-TP** One 802.3ab 1000BASE-T port, RJ-45 connector

CONSOLE CBL Industry standard serial cable, DB-9 connectors for RS-232 “ null-modem “ connection (sometimes called an X-modem cable), used to connect a PC or a character terminal to the Management port.

CONSOLE USB Industry standard serial cable, DB-9 connectors for RS-232 “ null-modem “ connection (sometimes called an X-modem cable) to connect to a managed switch, and a USB port to connect to a PC

DIN-RAIL-VRM DIN-Rail holder for a secure vertical mount of a 6K8-Series unit, with screws to attach to metal mounting brackets of the 6K8 case.

GarrettCom, Inc. reserves the right to change specifications, performance characteristics and/or model offerings without notice.

2.0 Introduction

2.1 Inspecting the Package and Product

Examine the shipping container for obvious damage prior to installing this product; notify the carrier of any damage that you believe occurred during shipment or delivery. Inspect the contents of this package for any signs of damage and ensure that the items listed below are included.

This package should contain:

- 1 Magnum 6K8-Series Industrial Field Switch, base unit
(configured with user-selected port module options installed)
- 1 AC Power Cord (U.S. and other 115 VAC only) if AC version
- 1 Set of two metal vertical mounting brackets, with screws to the case
- 1 Installation and User Guide (this manual)
- 1 Product Registration Card

Remove the items from the shipping container. Be sure to keep the shipping container should you need to re-ship the unit at a later date. To validate the product warranty, please complete and return the enclosed Product Registration Card to GarrettCom, Inc. as soon as possible.

In the event there are items missing or damaged, contact the party from whom you purchased the product. If the unit needs to be returned, please use the original shipping container if possible. Refer to Section 6, Troubleshooting, for specific return procedures.

NOTE: This Hardware user- manual only contains the hardware related information about the Magnum 6K8 and provides help for Network installation, wiring, and other hardware features. Refer to our [Software user Manual](#) for management software features and configurations (e.g. VLANs, RSTP, SNMP, RADIUS, TACACS etc.) using this URL- www.garrettcom.com/techsupport/software/userguides/6kseries_softugrel3.pdf

2.2 Product Description - Magnum 6K8-Series (6K8)

The Magnum 6K8-Series, Industrial Field Switch is the smallest member of the Managed 6K-Switch family. It is equipped with one module slot configurable to 8-ports. It is specially designed to meet industrial, power substation, and outdoor Ethernet specifications while fulfilling the needs of hardened applications. 6K8-Series managed field switches provide modularity of fiber and copper ports. They come with a combination of 10Mb, 100Mb and 1000Mb speed ports with comprehensive management software in a compact industrial-grade package. The combination of multiple possible configurations, multiple power options, a hardened enclosure, and MNS-6K management software makes the Magnum 6K8 a very powerful, effective and reliable managed Field Switch providing a secure solution for many needs.



Setting a new standard for Industrial and Carrier Class applications, heavy duty Ethernet Switch requirements are readily accommodated with an extended

temperature rating of -40°C to 60°C calculated by the UL Component Parts method, or -50°C to 95°C by the IEC 60068 calculated by the Type Test method. With various Power Supply options, such as all popular DC power input types, worldwide AC power and DIN-Rail mounting, the hardened Magnum 6K8-Series is a “multi-purpose” Industrial Ethernet Switch.

The extremely versatile options of various port modules offer all fiber media possibilities including small form factor (all connector types, multi- and single-mode) and 10/100 Mb auto-negotiating RJ-45 ports. Standard GBIC ports can be configured for a variety of Gigabit cabling types and distances. For details about module configurations please go to http://www.garrettcom.com/techsupport/insertion_guides/6k8cg.pdf

Advanced thermal design techniques (patent pending) transform the tough metal case into a heat sink as well as a shield for reducing electrical noise and providing physical protection. The unique design features an elongated dual-cavity shape for

optimal cooling of internal components without any ventilation openings. This sealed-case design enables the unit to operate in temperature un-controlled environments, achieve high EMI noise immunity and provide an un-matched IP53 physical protection rating against dust, dirt, insects, and liquid spills.

http://www.garrettcom.com/Pictorial/6k8_pictorial.pdf

High performance features include non-blocking speed on all ports and 802.1p QoS Traffic Prioritization. Magnum 6K8-Series switches are “plug-and-play” ready for use as backbone switches where a mix of bursty data traffic and priority streaming traffic for VoIP and audio/video “Triple Play” applications are present.

Magnum 6K8-Series Fiber Switches are provided with LAN management software including SNMP, Tag and Port-based VLANs, IGMP Snooping and Port Security with control via secure Web and command line interface (CLI). Loaded with secure features like- Radius server (802.1x), TACACS+, SNMPV3 and Port Security allow this Industrial Field Switch to qualify for a sub-standard managed switch to meet the Industrial expectation. For high availability, Redundant LANs using ring/mesh topologies, Spanning Tree Protocol, Rapid Spanning Tree Protocol, Link-Loss-Learn and S-Ring (ring only) are available. See the Managed Networks Software (MNS-6K) and S-Ring datasheets for additional details on the comprehensive set of software programs and options.

Magnum 6K8-Series, Industrial Field Switches have heavy duty metal cases and auto-ranging power supplies for operation with standard AC power worldwide. Internal DC power supplies are optional. All DC power input types (24V, 48V, 125V) are supported, and dual source input is optional.

Alarm Relay contacts provided on each Magnum 6K8-Series Switch are monitored via the hardware and software providing a loss of power signal and user-defined software events through traps. See Section 3.5 for details.

The wide selections of port modules are key to the flexibility and adaptability.

2.2.1a Magnum 6K8-Series, Industrial Field Switch

The Magnum 6K8-Series is primarily designed for use in vertical mount applications. Equipped with multi-media fiber/copper solutions, multiple speed 10/100/1000Mb support, rich MNS-6K management features, hardware and software alarms and convection cooling (no fans), the Magnum 6K8 easily qualifies for use in transportation

and traffic control systems, power utilities and industrial factory-floors. For the fast growing demands of video surveillance systems with segments requiring Gigabit backbone interconnections, the Magnum 6K8 managed switches are easy to install and operate with Magnum 6K management firmware.

The advanced generation of industrial applications requires advanced managed network software, operation at extended temperatures, fiber ports modularity, support for self-healing ring structures, redundancy, security and gigabit backbone configurability. The Magnum 6K8 has all of these, in a very tough and robust metal case with a wide choice of popular DC options or industry standard AC internal input.

The plug-n-play Magnum 6K8 Industrial Field switches, should be mounted vertically using the vertical mounting brackets which come along with the unit or by using the DIN-RAIL-KIT (optional) for Din rail mounting.

Loaded with versatile and secured management software (MNS-6K), the 6K8 switch can be easily managed and monitored via SNMP or secured Web. Supporting dual Gigabit ports (copper or fiber) in one slot defines the Magnum 6K8 Field switches role as an effective **Managed Gigabit media converter Switch** that meets any secured Gigabit media requirements.

Dual LEDs on the front and Top side help the vertically mounted 6K8 to be monitored easily. The modular designed Magnum 6K8 Industrial Field switch can support a maximum of two Gigabit modules (fiber or copper) to meet any demand of bandwidth required applications. In an on-going demand of diversified designed Ethernet applications, the Magnum 6K8 is a fine solution to meet and satisfy any requirements through its rich modular structure. The Relay contact for external “ALARM” is another additional feature which allows the Magnum 6K8 to monitor the internal power failure



and controlled via hardware or software trap controls. The options for universal AC and 24V/-48V/125VDC power options offer a widely accepted managed switch with high reliability.

2.2.2 Eight-port SFF fiber modules (6K8-MTRJ, 6K8-MLC), 100Mb fiber



Fig.2.2.2 :
SFF Fiber Port
Modules,
6K8-MTRJ (to the left)
and
6K8-MLC or -SLC
(below)

In an eight-port SFF fiber port module, all of the fiber ports are of the same speed (100Mb), mode, and connector type. Models available with Small Form Factor (SFF) are multi-mode MT-RJ or LC-type connectors, and single-mode LC-type connectors.

The 100Mb fiber eight-port modules for the Magnum 6K8-Series normally are set (factory default) to operate in full-duplex mode for best fiber distance and performance. Using the 6K-MNS software, the user may

select full- or half-duplex mode per-port through set-up of the software (See Magnum 6K-MNS Software Manual) for the flexibility to adapt to any FDX or HDX type of Fast Ethernet devices).

There are three LED's per fiber port. The Link (LK) LED indicates "ready for operation" on that port when lit, the F/H LED indicates operation in full-duplex mode when ON (half-duplex when OFF), and the blinking ACT LED indicates receiving Activity on the port. A fiber cable must be connected into a SFF port and the Link (LK) indicator for that port must be ON (indicating there is a powered-up device at the other end of the cable) in order for a LK LED to provide valid indications of operating conditions on that port.

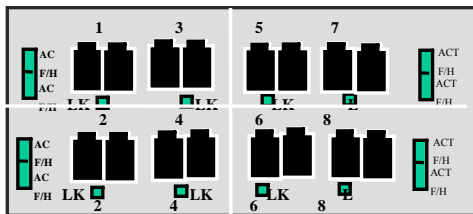

2.2.3 Eight-Port Copper Module, 6K8-RJ45

The 6K8-Series's 8-port Copper port module, model 6K8-RJ45, provides eight 10/100Mb switched RJ-45 ports. The 10/100Mb switched ports normally (as a default setting) are independently N-way auto-negotiating, and auto-crossover(MDIX) for operation at 10 or 100Mb speed in full- or half-duplex mode, i.e., each independently selects a mode and speed to match the device at the other end of the twisted pair cable.

(See Section 4.3 for auto-negotiation and MDIX details). The auto-crossover feature will automatically determine the other side of connection to make the connection, and eliminate the need of cross-over cable.

On the model 6K8-RJ45 module, there are four LEDs for each port, two in the connector and two separate. The LK (Link) LED indicates "ready for operation" on that port when lit. The blinking ACT (Activity) LED indicates receiving Activity on that port when lit. The 10/100 LED indicates operation at 100Mb speed when ON and at 10 Mb speed when OFF (when auto-negotiation is not disabled). The FDX/HDX LED is ON to indicate full-duplex operation and OFF to indicate half-duplex mode. A twisted pair cable must be connected into an RJ-45 port and the Link (LK) indicator for that port must be ON (indicating there is a powered-up device at the other end of the cable) in

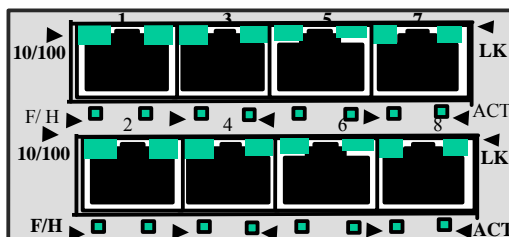

order for a LK LED to provide valid indications of operating conditions on that port.

Using the 6K8-Series (MNS-6K) management software, the user may disable auto-negotiation and fix the desired operation of each RJ-45 port. User may select 10Mb or 100Mb speed and full- or half-duplex mode per-port as per user requirement. (See Magnum MNS-6K Software Manual for details info.).

2.2.4 Six-Port "4 + 2" Combo Modules, 4@ 10/100 RJ-45 and 2@ 100Mb fiber

4@RJ-45 + 2@ 100Mb

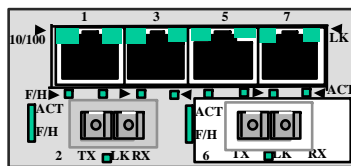
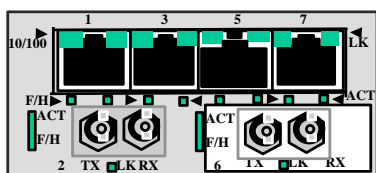

ST or SC

The combo six-port modules are combinations of copper and fiber media, available as four 10/100 switched RJ-45 copper ports and two 100Mb switched multi-mode fiber in either ST, SC, single mode SC or Long Reach SC ports. For port numbering, ports 1,3,5,7 are copper, ports 2 and 6 are fiber, and ports 4 and 8 are not present.

The four RJ-45 ports operate just like the 8-port copper module with auto-cross

(MDIX) features to eliminate the use of cross-over cables. The two fiber ports operate at 100Mbps full-duplex (default). User mode control per port through the MNS software is also the same.

On Magnum “4+2” Combo modules, there are four LED’s for each RJ-45 port, which indicate status as described for the 6K8-RJ45 in Section 2.2.3 above. The fiber port LEDs indicate status the same way as described for the SFF fiber modules in Section 2.2.2 above. Color-coding on the panel of the module shows which LEDs belong to which port.

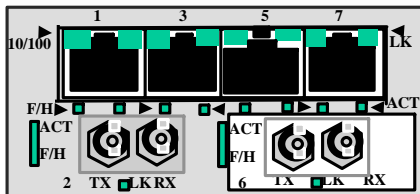

The Magnum Combo six-port modules are also available with 4@ MTRJ 100Mb mm SFF fiber and 2@10Mb fiber mm ST ports, or 4@ RJ45 10/100 copper and 2@10Mb fiber mm ST ports. The

4@ RJ-45 + 2@ 10 Mb ST operation of the SFF fiber and the RJ-45 half of the module is as described for those port types above. For detailed information about 10Mb mm ST fiber half of the module, see Section 2.2.5.

2.2.5 Four-Port 10 Mb and 100Mb mm Fiber ST Modules



The 4-port @10Mb ST fiber modules behave the same as the 4@100Mb ST fiber modules except for the 10Mb speed. For port numbering, ports 1, 2, 5, 6 are present, ports 3, 4, 7, 8 are not present. There is also a similar 100Mb fiber SC module.

The default setup on the 10Mb fiber module is half-duplex, which allows the Magnum 6K8-Series Switch to connect to any 10Mb hub or media converter or almost any other device with a 10Mb fiber Ethernet port. The default setting of the 100Mb fiber module is full duplex. User mode-control per port through the MNS “port settings” software is the same as the other 6K8-Series modules.

The fiber ports support fiber-cabling distances according to the 10BASE-FL and 100BASE-FX standards, i.e., 2km distance for multi-mode fiber. (Single-mode for up to greater distance may be available as a special order, request quote).

2.2.6 Gigabit (1000Mbps) port modules

The Magnum 6K8-Series offers a wide range of optional Gigabit modules and one or two Gigabit ports can be configured in one modular slot. The Gigabit modules are the two port GBPMV-2OTX , the 6KP5V-G4RJ (single Gigabit+4 10/100 RJ-45 ports) or the 6KP3V-G2SC (single Gigabit+2 100Mb fiber ports) as shown below in the figure.

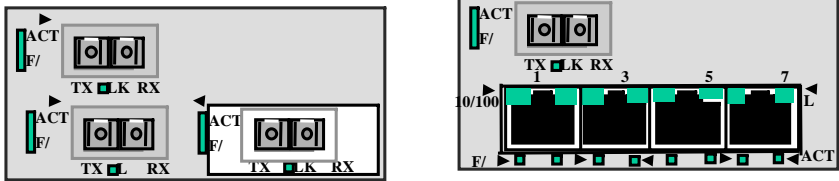

1@ 1000Mb Fiber SC + 2@ 100Mb SC

1@ 1000Mb Fiber SC + 4@ 10/ 100Mb

The 6K8-Series Modules provide a GBIC opening for insertion of industry-standard GBICs to provide Gigabit media flexibility. GBIC models are available for both multi-mode (550m) and single-mode (10, 25, 40, 70) km fiber options. Gigabit copper is also available with new models appearing often.

The 1000Mb Gigabit fiber-port modules on the Magnum 6K8-Series are normally set (factory default) to operate at AUTO mode for best fiber distance and performance. The 1000Mbps SC fiber-optic module on the Gigabit -SX and Gigabit-LX transceivers are compatible with the IEEE 802.3z Gigabit standards.

There are two LEDs mounted on each Gigabit port module. The Gigabit fiber port is by default configured to AUTO mode, and can be fixed at 1000Mbps speed full-duplex mode at any time. The Gigabit fiber port has LEDs that indicate LK (Link status) and ACT (receiving activity) on that port when lit.

NOTE: For detail information about the various port module 6KPMV options being used for Magnum 6K8, please check section 5.2, 6KPM Module Description.

2.2.7 Packet Prioritization, 802.1p QOS

Quality of Service means providing consistent predictable data delivery to users from datagram paths that go all across a network. As a LAN device, the Magnum 6K8-Series can do its part to prevent any QOS degradation while it is handling Ethernet traffic through its ports and buffers.

The Magnum 6K8-Series switching hardware supports the IEEE 802.1p standard and fulfills its role in support of QOS, giving packet processing priority to priority tagged packets according to the 802.1p standard. In addition to hardware support for QOS, the MNS software (Rel3) supports two priority queues that can be shared across the eight levels of defined packet priorities for application-specific priority control by the user through software configuration settings.

2.2.8 Frame Buffering and Flow Control

Magnum 6K8-Series's are store-and-forward switches. Each frame (or packet) is loaded into the Switch's memory and inspected before forwarding can occur. This technique ensures that all forwarded frames are of a valid length and have the correct CRC, i.e., are good packets. This eliminates the propagation of bad packets, enabling all of the available bandwidth to be used for valid information.

While other switching technologies (such as "cut-through" or "express") impose minimal frame latency, they will also permit bad frames to propagate out to the Ethernet segments connected. The "cut-through" technique permits collision fragment frames (which are a result of late collisions) to be forwarded which add to the network traffic. Since there is no way to filter frames with a bad CRC (the entire frame must be present in order for CRC to be calculated), the result of indiscriminate cut-through forwarding is greater traffic congestion, especially at peak activity. Since collisions and bad packets are more likely when traffic is heavy, the result of store-and-forward operation is that more bandwidth is available for good packets when the traffic load is greatest.

When the Magnum 6K8-Series Switch detects that its free buffer queue space is low, the Switch sends industry standard (full-duplex only) PAUSE packets out to the devices sending packets to cause "flow control". This tells the sending devices to temporarily stop sending traffic, which allows a traffic catch-up to occur without dropping packets. Then, normal packet buffering and processing resumes. This flow-control sequence occurs in a fraction of a second and is transparent to an observer. Another feature implemented in Magnum 6K8-Series Switches is a collision-based flow-control mechanism (when operating at half-duplex only). When the Switch detects that its free buffer queue space is low, the Switch prevents more frames from entering by forcing a collision signal on all receiving half-duplex ports in order to stop incoming traffic. The flow control option is user configurable (enable/disable) through the *setport* command of MSN-6K software as per the requirement of a network.

2.2.9 Managed Network Software (MNS-6K) for Magnum 6K8-Series

Magnum 6K8-Series comes with licensed MNS-6K Firmware (Rel 3.2), which allows the configuration of the Magnum 6Ks as a Managed Switch and also allows other Software enabled features. For additional information about MNS-6K, see the Magnum 6K8-Series MNS **Software User guide** in pdf format, a separate document normally accessed via your web-browser, at <ftp://ftp.garrettcom.com/>

or FTP client program at <ftp.GarrettCom.com> . Use the following to log in.

```
user : m6kuser
```

```
password : m6kuser
```

All MNS-6K software information, including new releases and upgrades related to MNS-6K software can be accessed and download from GarrettCom's FTP site.

Alternatively, for documentation and latest information, or needed

GarrettCom proprietary MIBs for SNMP- please go to

www.GarrettCom.com/techsupport/index.htm#software and look for Magnum MNS-6K info.

[Magnum MNS-6K Operator Training](#) – This interactive training software instructs on all the basic and advanced information about the Magnum MNS-6K management software and is a useful tool for the first time user.

Finally, please email: support@GarrettCom.com for further information.

For **upgrading the Magnum 6K8 Switch** to its latest Magnum 6K-Firmware, follow through the steps and instruction provided on -

http://www.garrettcom.com/techsupport/software/upgrade_mns6k.pdf

2.3 Features and Benefits

■ **Managed switching for high performance Ethernet LANs**

Magnum 6K8-Series Switches provide non-blocking (all ports can run at full speed at once) performance with standard Managed Networks Software (MNS-6K) included. They are typically used in LAN traffic centers with 16 100Mb or 8+2 Gigabit ports for backbone connections, where managed network services are desired.

■ **Switching services includes 802.1p QoS packet prioritization**

The Magnum 6K8-Series switching hardware supports QoS, giving packet processing priority to priority tagged packets according to the IEEE 802.1p standard. For port- and application-specific priorities of data, the QoS software may be configured.

■ **Large selection of built-in fiber options at 10/100/1000Mb**

Magnum 6K8-Series Industrial Field Switches are designed to naturally include fiber ports, and support mixes of multi-mode and single-mode; 10 Mb, 100Mb and 1000Mb speed; full- and half-duplex; classic Small Form Factor (SFF) and GBIC fiber connectors. RJ-45 10/100 ports can also be configured in the mix of port types.

■ **S-Ring and Link Loss Learn for reliable high availability using ring topology**

S-Ring and Link-Loss-Learn provide reliable fast recovery of a fault in ring topology.

■ **Relay Contacts for monitoring internal power and user-defined software events**

Two Alarm Relay contacts monitor basic operations. One is for hardware, and will signal loss of power internally. The other is software controllable and will signal user-defined software event traps such as a security violation or an S-Ring fault condition.

■ **Vertical mounting for efficient convection cooling, no fans, extended temp.**

Vertical mounting brackets are included. DIN-Rail mounting hardware is optional. Ethernet signal and power cables attach in the bottom. Two sets of status LEDs are on the switch, one set viewable at the port connector and one set viewable from the front.

■ **Standard AC power input, -48VDC or 24VDC or 125VDC input is optional**

Standard AC power input is IEC plug, auto-ranging for worldwide use. For special applications, models with -48VDC or 24VDC or 125VDC are available. Dual Source DC input can also be selected and configured on the DC power input models.

■ **Heavy-duty design, for Industrial Ethernet and un-controlled temp. operation**

Fiber ports take more power than copper ports, but the Magnum 6K8-Series design provides for this with heavy-duty components. The ambient temperature dual-rating is 60°C per UL methods, and 95°C per type test methods.

■ **MNS-6K licensed Network Management Software included, S-Ring optional**

Release 3.1.2 (fall '05) includes SNMP Switch Management with secure access control, RMON, CLI, Port Security; Port Mirroring; Port Settings Control; Telnet, TFTP, FTP support, Spanning Tree Protocol, Link-Loss-Learn, S-Ring (with license key) multi-level QoS, Port- and tag-based VLANs, GVRP, IGMP Snooping, SNMPc GUI support; Event Log; SNTp client for time-of-day; BootP and DHCP client for IP configuring, and password security. Secured Web Management, RADIUS X and TACACS+. MNS-6K software is factory installed, supported and updated via Internet and GCI FTP Server.

2.4 Applications

Magnum 6K8-Series Fiber Switches offer high performance, modularity and higher availability to provide an effective solution for Industrial Ethernet needs. They provide the flexibility of 100Mbps fiber and copper ports as well as single or dual Gigabit(1000Mb) ports, with industry-standard MNS-6K software. Magnum 6K8-Series Switches are easily used in a variety of applications including client/server computing, secure VLAN- performance upgrades to departmental networks, and stream traffic for VOIP and audio/video applications for a diversified combination of mixed media for monitoring and signaling in Industrial floor applications. The performance characteristic of the 6K8-Series Switches enable them to inter-connect a series of subnets (one subnet per 6K8-Series Switch port) in a LAN traffic center. The subnet connections may be via fiber or twisted pair cabling, 1000Mbps, 100Mbps or 10 Mbps speed, and full-or half-duplex.

The mixed-media modular capability is ideal for Industrial applications where existing Ethernet LAN network cabling must be accommodated. The fiber-built-in media capability is ideal for integrating future-proof fiber cabling into the LAN structure.

Example 1 : Magnum 6K8-Series Switch for a Industrial application

Equipped with lots of useful features such as a hardened Industrial enclosure, a wide spread of AC/DC power supply options, extended temperature rating and secured management features qualifies the Magnum 6K8-Series Managed switch for any Industrial factory-floors, traffic control, transportations systems, monitoring and signaling and power utilities applications. The bundle of MNS-6K software operated features diversifies this managed switch to operate and perform securely and reliably in all critical applications. The addition of the *S-Ring* and *Link-Loss-Learn* software feature allows this Managed switch to provide a very reliable highly available redundant network capability in any ring topology network.

In an Industrial environment where the factory floors are networked with Ethernet based mixed-media LANs and equipped with PLC computers to take readings and data from M/C Client/ Server databases and transport this important data to the central office data warehouses the Managed 6K8-Series shines. The Managed 6K8-Series's modularity along with MNS-6K management software features handle these kinds of networks very securely and reliably through out the Factory-floors. The DIN-Rail Mounting options on the Magnum 6K8-, allow the Industrial Factory floor user to

mount the 6K8 securely anywhere on their Network setup.

The option for setting the ports at 10 or 100Mb on copper, and supporting the 10 or 100Mb fiber media, provide widespread options to the users to mix and match their legacy and advance network needs. The modularity of the 6K8-Series Industrial Field Switch makes it an attractive choice for use in applications with LAN connections to an organization's multiple site offices and factory- floors. The different locations can be easily connected together with the Fiber ports supported by the Magnum 6K8-Series Switch. A main NT-server in a secure area protected from earthquake or fire hazards can be connected to the full duplex Gigabit Fiber port.

Extended temp.ratings, 24V/125VDC power supply options, and IP53 approval qualifies this managed 6K8-Series switch for use in temp. un-controlled network floors and many others temp sensitive critical Industrial applications where above normal room temp. is present in the room the network operates. Full-duplex future proof fiber media can easily connect long distance subnets and provide a stable secure network to all applications. The SNMP, QOS management capability of the Magnum 6K8-Series Switch helps create a database of all the network subnets to easily manage the network and prioritize the sensitive and useful data. The Relay contact for the Alarms feature operated through software and hardware provides extra reliability to monitor the switch operation or any power failure.

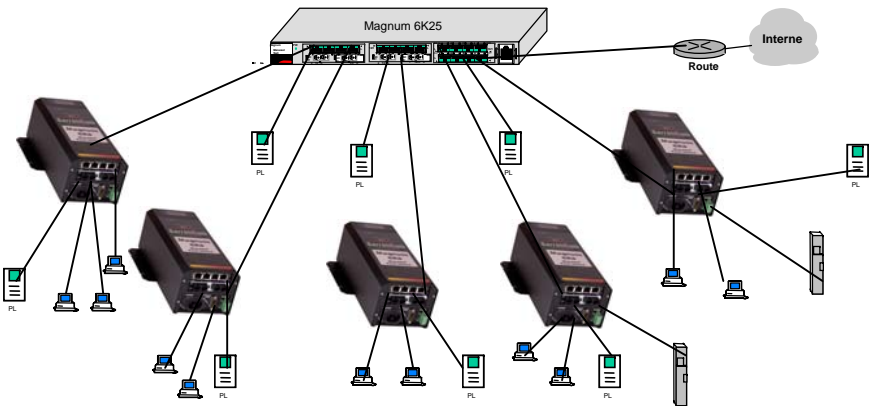

Magnum 6K8 in a Industrial floor application to monitor and signaling PLC units

Example 2. In another outdoor Ethernet Traffic monitoring application, a managed network is needed to provide a Redundant ring topology for a maximum redundant network. This is needed where any faulty cable, cable disconnection or power failure in a ring switch needs to be reconfigured in milliseconds. The ring topology of the network consists of high speed LAN segments supported by 100Mbps full-duplex future-proof fiber media to provide secure long distance LAN connections. The entire network is sharing a higher bandwidth of multicast packets used for secure camera monitoring and data-mining for the vital database located in a controlled center secured building. The entire spread network will be manageable to provide easy, detectable, uninterrupted support through a viewable SNMP monitor.

The NEMA TS-2 and TEES along with IP53 approval with the mix of copper and fiber ports on the 6K8-Series Industrial Field Switch provides an economical and seamless solution to the requirements. The user-configurable Magnum 6K8 provides an extra boost to the network requirements by providing copper/fiber media along with the higher bandwidth support of 10/100Mbps. The user can utilize the SNMP feature equipped with 802.1Q VLAN, RMON, RSTP and other standard managed LAN features to provide a secure and stable network.

The 6K8-Series Industrial Field with S-ring and Link-Loss-Learn feature easily fulfilled the redundancy requirement in a secure and fast reconfiguration time for cable breakup by setting up a ring topology.

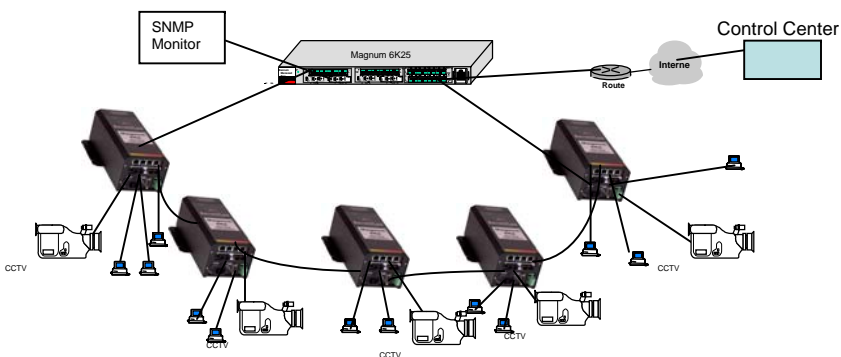
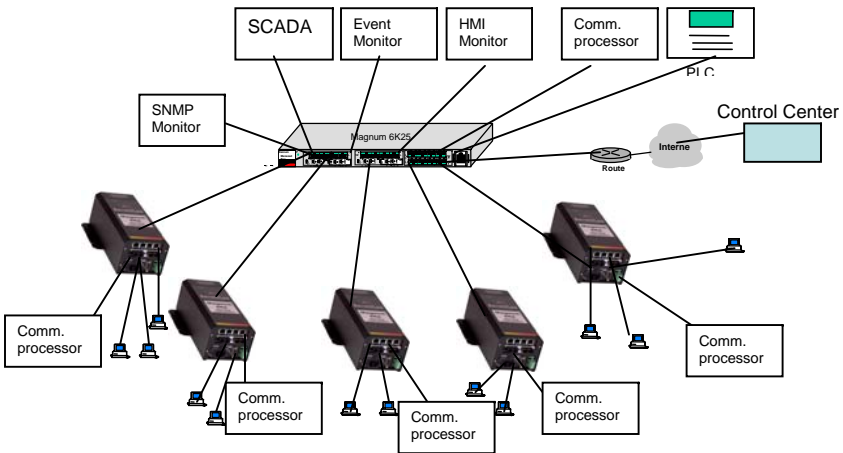

Fig. 2.4b-Magnum 6K8 equipped with S-Ring in redundant ring in a outdoor Traffic application

Example 3: In another example, a large Power Substation (Electric and Gas) needs a Secure Ethernet LAN network to collect, monitor and provide a simplified communications backbone for local and remote control of real-time operational and fault analysis data. The Ethernet backbone should pass the information of SCADA local monitoring and control via a HMI. The heart of the system evolves around several communications processors.

The Hardened enclosed 6K8-125VDC Industrial field switch with IEEE 1613 and IEC61850 approved for power stations is equipped with its modularity, secured management features, un-controlled temp ratings along with a hardware/software controlled Alarm Relay which easily qualifies it to provide all the requirements of substations.

The successful track record of previous members of the 6K-family in substations also adds another example of success for this product to deploy in sub-station environments. The combination of 6K25 as the back bone and 6K8 at the edge provides a seamless secure solution which can easily monitor real-time operations. Enriched with Fiber and copper options make this switch ready to provide this solution and also control any emission noises via a fiber approach.



Magnum 6K8 Industrial Field switch in a Power Substations applications

3.0 Installation

Before installing the equipment, please note the following UL/CSA60950 product safety listing requirements.

1)The external power supply for 24VDC units shall be a Listed, Direct Plug In power unit, marked Class 2, or a Listed ITE Power Supply, which has a suitably rated output voltage (i.e. 24VDC), and suitably rated output current.

Mounting Instructions -

A) Elevated Operating Ambient - If installed in a closed or multi-unit rack assembly, the operating ambient temperature of the rack environment may be greater than room ambient. Therefore, consideration should be given to installing the equipment in an environment compatible with the maximum ambient temperature (T_{ma}) specified by the manufacturer.

B) Reduced Air Flow - Installation of the equipment in a rack should be such that the amount of airflow required for safe operation of the equipment is not compromised.

C) Mechanical Loading - Mounting of the equipment in the rack should be such that a hazardous condition is not achieved due to uneven mechanical loading.

D) Circuit Overloading - Consideration should be given to the connection of the equipment to the supply circuit and the effect that overloading of the circuits might have on over current protection and supply wiring. Appropriate consideration of equipment nameplate ratings should be used when addressing this concern.

E) Reliable earthing of rack-mounted equipment should be maintained. Particular attention should be given to supply connections other than direct connections to the branch circuit (e.g. use of power strips).

F) Replacement of fuses should be only by qualified service personnel.

G) A readily accessible disconnect device shall be incorporated in the building installation wiring.

H) When connected to a 48 V centralized dc source, this product is to be installed only in Restricted Access Areas (Dedicated Equipment Rooms, Electrical Closets, or the like) and shall be provided with a Listed 5 A DC fuse or circuit breaker in the supply circuit.

This section describes installation of the Magnum 6K8-Series Switches, as well as connection of the various Ethernet media types.

3.1 Locating Magnum 6K8-Series Switches

For vertical panel mounting and wall mounting, see Section 3.4.

For vertical DIN-Rail mounting, see Section 3.3.

For DC power options, see Appendix B. For Dual Source, see Appendix C.

For AC power input, locate an AC receptacle that is within six feet (2 meters) of the intended Magnum 6K8-Series site. The rugged metal case of the Magnum 6K8-Series will normally protect it from accidental damage in a lab or workplace setting. Maintain an open view of the front to visually monitor the status LEDs. Keep an open area around the unit so that cooling can occur from convection while the unit is in operation. The 6K8-Series has no fans, so it is silent when in operation. Internal electronics use the case as a heat sink, so the unit may normally be quite warm to the touch.

3.2 Connecting Ethernet Media

The Magnum 6K8-Series Switches are specifically designed to support all standard Ethernet media types within a single Switch unit. This is accomplished by using a family of different port Modules which can be individually selected and configured per-port. See Section 2.4 for a description of the PMs.

The various media types supported along with the corresponding IEEE 802.3, 802.3D, 802.3u, 802.3AB and 802.3z standards and connector types are as follows:

<u>IEEE Standard</u>	<u>Media Type</u>	<u>Max. Distance</u>	<u>Port Module</u>
<u>Fiber:</u>			
1000BASE-FX	mm ¹ Fiber	220m (ft)	GBIC-SXSC
	sgl.m ² Fiber	5,10,25,70Km	GBIC-LXSC
100BASE-FX	mm ¹ Fiber	2.0km (6,562 ft)	6K6-MSC, -MST
	sgl.m ² Fiber	18.0km (95K ft)	SSC, SSCL
small form factor	mm ¹ Fiber	2.0km (6,562 ft)	6K8-MTRJ, -MLC
small form factor	sgl.m ¹ Fiber	15 km	6KP8V- SLC
<u>Copper:</u>			
10BASE-T,100BASE-TX twisted pair		100m (328 ft)	6K8-RJ45
1000BASE-TX			GBPM-RJ45

¹ mm = multi-mode

² sgl.m = single-mode

3.2.1 Connecting Fiber Optic ST-type, “twist-lock”

The following procedure applies to installations using a PM with ST-type fiber connectors. This procedure applies to ports using a 6K8-Series module, MST-type port.

1. Before connecting the fiber optic cable, remove the protective dust caps from the tips of the connectors on the PM. Save these dust caps for future use.
2. Wipe clean the ends of the dual connectors with a soft cloth or lint-free lens tissue dampened in alcohol. Make certain the connectors are clean before connecting.

Note: *One strand of the duplex fiber optic cable is coded using color bands at regular intervals; you must use the color-coded strand on the associated ports at each end of the fiber optic segment.*

3. Connect the Transmit (TX) port (light colored post) on the Magnum PM to the Receive (RX) port of the remote device. Begin with the color-coded strand of the cable for this first TX-to-RX connection.
4. Connect the Receive (RX) port (dark colored post on the PM) to the Transmit (TX) port of the remote device. Use the non-color coded fiber strand for this.
5. The LINK LED on the front of the PM will illuminate when a proper connection has been established at both ends (and when power is ON in the unit). If LINK is not lit after cable connection, the normal cause is improper cable polarity. Swap the fiber cables at the PM connector to remedy this situation.

3.2.2 Connecting Fiber Optic **SC-type, "Snap-In"**

The following procedure applies to installations using a PM with SC-type fiber connectors, i.e., using 6K-MSC, 6K-SSC single-mode.

While connecting fiber media to SC connectors, simply snap the two square male connectors into the SC female jacks of the 6KPM module until it clicks and secures.

3.2.3 Connecting **Single-Mode** Fiber Optic

When using single-mode fiber cable, be sure to use single-mode fiber port connectors. Single-mode fiber cable has a smaller diameter than multi-mode fiber cable (9/125 microns for single-mode, 50/125 or 62.5/125 microns for multi-mode where xx/xx are the diameters of the core and the core plus the cladding respectively). Single-mode fiber allows full bandwidth at longer distances, and may be used to connect 10 Mb nodes up to 10 Km apart, or 18Km with the 6K-SSC.

The same procedures as for multi-mode fiber, applies to single-mode fiber connectors. Follow the steps listed in Section 3.2.2 above.

3.2.4 Connecting Twisted Pair (**RJ-45, CAT3, CAT5, Unshielded or Shielded**)

The RJ-45 ports of the Magnum 6K8-Series can be connected to the following two media types: 100BASE-TX and 10BASE-T. CAT 5 cables should be used when making 100BASE-TX connections. When the ports are used as 10BASE-T ports, CAT 3 may be used. In either case, the maximum distance for unshielded twisted pair cabling is 100 meters (328 ft).

<u>Media</u>	<u>IEEE Standard</u>	<u>Connector</u>
Twisted Pair (CAT 3, 4, 5)	10BASE-T	RJ-45
Twisted Pair (CAT 5)	100BASE-TX	RJ-45

NOTE : *It is recommended that high quality CAT. 5 cables (which work for both 10 Mb and 100Mb) be used whenever possible in order to provide flexibility in a mixed-speed network, since dual-speed ports are auto-sensing for either 10 and 100Mb/s.*

The following procedure describes how to connect a 10BASE-T or 100BASE-TX twisted pair segment to the RJ-45 port. The procedure is the same for both

unshielded and shielded twisted pair cables.

1. Using standard twisted pair media, insert either end of the cable with an RJ-45 plug into the RJ-45 connector of the port. Note that, even though the connector is shielded, either unshielded or shielded cables and wiring may be used.
2. Connect the other end of the cable to the corresponding device
3. Use the LINK LED to ensure proper connectivity by noting that the LED will be illuminated when the unit is powered and proper connection is established.
4. The auto-cross(Auto-MDIX) feature will eliminate the use of crossover cable, while connecting the RJ-45 ports to any other RJ-45 device.

3.2.5 Connecting Twisted Pair (CAT5E or better, Unshielded or Shielded)

The RJ-45 Gigabit ports of the Magnum 6K8-Series can be connected to the media types, 1000BASE-T or CAT 5E or better 100-ohm UTP or shielded twisted pair (STP) balanced cable. The CAT 5E or better 100-ohm UTP or shielded twisted pair (STP) balanced cable is recommended to use when making 1000BASE-TX connections. In either case, the max distance for unshielded twisted pair cabling is 100 meters (328 ft).

<u>Media</u>	<u>IEEE Standard</u>	<u>Connector</u>
Twisted Pair (CAT 5E)	1000BASE-T	RJ-45

NOTE : *It is recommended that high quality CAT. 5E cables (which work for both 100 Mb and 1000Mb) be used whenever possible in order to provide flexibility in a mixed-speed network.*

The following procedure describes how to connect a 1000BASE-T twisted pair segment to the RJ-45 port. The procedure is the same for both unshielded and shielded twisted pair cables.

1. 1000Base-T connections require that all four pairs or wires be connected. Insert either end of the cable with an RJ-45 plug into the RJ-45 connector of the port. Note that, even though the connector is shielded, either unshielded or shielded cables and wiring may be used.
2. Connect the other end of the cable to the corresponding device
3. Use the LINK LED to ensure proper connectivity by noting that the LED will be illuminated when the unit is powered and proper connection is established

3.2.6 Connecting Gigabit Media Using GBICs

The Gigabit ports accept industry-standard GBICs for user selection of the gigabit media type desired. A selection of fiber and copper GBICs are available.

3.3 DIN-Rail Mounting

The Magnum 6K8 is designed for use in a “factory floor” industrial environment. It is available with optional DIN-Rail brackets to mount it securely in a metal factory



floor enclosure, maintained vertically for proper convection cooling of the unit. The Magnum 6K8 requires two DIN-Rail mounting clips or latches for secure mounting, and these may be ordered as Model # DIN-RAIL-6K8. See a 6K8 viewed from the rear, at right, with model DIN-RAIL-6K8 in place on the unit.



The Din Rail Latching clips are mounted on the upper rear corners of the 6K8 unit. Two threaded holes are provided on the sides of 6K8 for DIN-Rail mounting purposes. See side view at the left, with the top of the unit pointed to the right. The required two screws are included with the DIN-Rail brackets, and are no.10-32 X 3/8 PHIL. PAN w/star washer. The two heavy duty Din-Rail

latches are designed as if that they can be manually accessed from the top when the 6K8 is installed on a DIN Rail.

To install the 6K8 with the DIN-Rail brackets and latches attached to it, hold the 6K8 in the vertical position with the bottom out, and with the top moved in toward the DIN-Rail. Position the latches over the top of the DIN-Rail. Then, snap the latches into holding position by moving the bottom of the 6K8 inwards to a vertical position. The DIN-Rail latches and brackets are heavy duty, and will hold the 6K8 securely in position, even with cabling attached to the unit.

To release the 6K8 from the DIN-Rail mounting, press the top of the two DIN-Rail latches down simultaneously to release the 6K8 so that it can be dismounted by pulling the bottom out. Once the bottom of the 6K8 is rotated out, the DIN-Rail latch is not engaged and the 6K8 can be moved up and out, free of the DIN-Rail mounting..

The picture below is a front / right-side view of a DIN-Rail mounted 6K8. It shows vertical mounting of Magnum 6K8 on a DIN-Rail track for proper convection cooling of the unit. Note that there is air space in the rear, as the 6K8 unit is held out from the rear of the panel by the mounting brackets. The 6K8 design uses the case for cooling (patent pending), and needs to be mounted vertically with air flow space in the front, rear, and sides.

Fig 3.3 - Magnum 6K8 mounted vertically with DIN-Rail brackets and latches

The DIN-Rail mounting brackets and latches are optional and need to be ordered as separate items, e.g Model # DIN-RAIL-6K8

3.3.1 Installing DIN-RAIL variable brackets on Magnum 6K8

Magnum 6K8 Din-Rail kit comes along with the following-BOM:

Item	Quantity	Description
1	1	DIN Rail Clip assy
2	2	#10-32 x ¼ Phillip undercut
3	8	#4-40 x 3/8 Phillip Flat head screw



Flat head screws with

Din-Rail kit Installation procedures:

1. Remove the back plate from Magnum 6K8 UNIT
 - a. There are eight screws along the edge of the unit to remove.
 - b. Do not re-use the old screws.
2. On the back-plate
 - a. Locate the indented side with 1, 11.....
 - b. "1" indentation signify center of the mounted Din-Rail clip location.
 - c. Each indented locations (1-11-111...) are ½ inches apart from the center.



Fig 1.

3. Select the height position via indented side marking .

4. Place the DIN Rail Clip assembly under indented side of the plate. Place two of the screws, came along the kit (#10-32 x ¼ Phillip Flat head screws with undercut) onto the indented side and screw tight the assembly as shown in Fig 2a.

Note: Make sure the screws must have the 5lbs/in torque minimum.

a. The Din-Rail clip must be on top, while positioning the clip as shown in Fig. 2b with arrow mark.

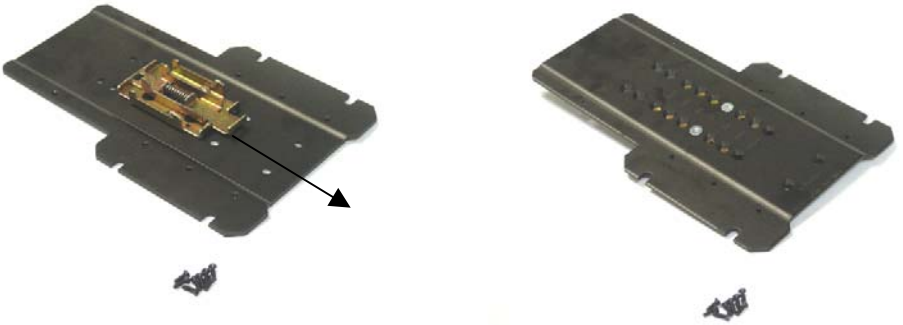

Fig. 2a: 10-32 Screws on indented side Fig. 2b: Din-Rail assembly w/plate applied to mount the Din-Rail assembly underneath.

5. Remount the Din-Rail assembled plate onto the Magnum 6K8, using the 4-40 screws.

Note: Torque 5lb/in max. on the 4-40 screws while tightening the screws.

The final Din-Rail assembly mounted on the Magnum 6K8 is shown below on Fig. 3

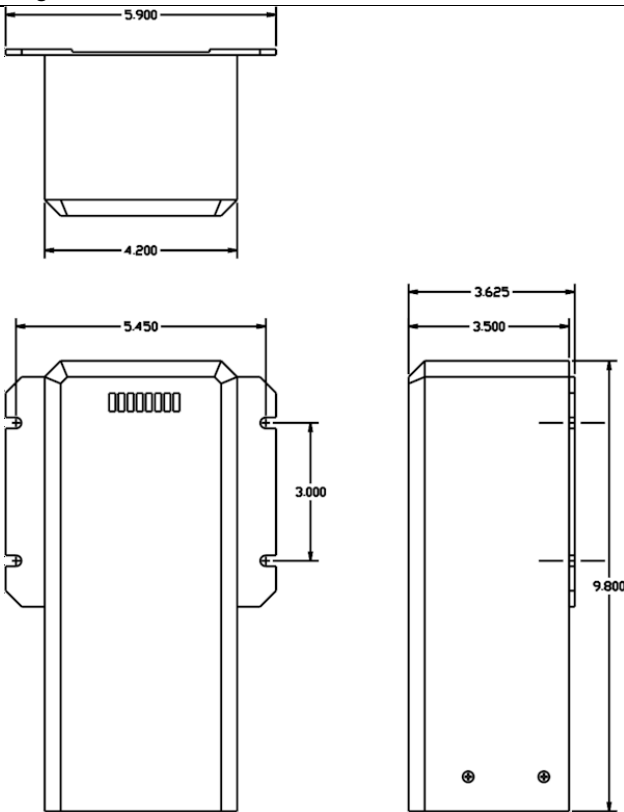

Fig . 3

3.3.2 Mounting Dimensions for 6K8 with metal brackets

Each Mangum 6K8 is supplied with metal mounting brackets and screws to mount the unit securely. It is recommended to mount the 6K8 vertically, as shown below, for proper cooling and long-life reliability. It is also advisable to mount the unit with space for air movement around the top and the sides, typically a minimum of 1 inch..

Note that the back of the 6K8 unit is held out from the panel or wall behind it, creating a rear space of about $\frac{1}{4}$ inch or 1cm. This allows air circulation and cooling of the rear part of the case. Since the 6K8 uses special internal thermal techniques (patent pending) to move the heat generated by the electronic components inside into the case, the case may be quite warm to the touch during normal operation.



The unit can be mounted using the brackets turned outside (normal) or inside (if space is tight). Attach the mounting bracket either outside or inside as shown in the illustration above (dotted line shown for the brackets inside). The spacing for the mounting screws into the supporting wall or panel is a rectangle 11.89" x 7.85" center-to-center.

3.4 Powering the Magnum 6K8-Series Industrial Field Switch

The Magnum 6K8-Series Switches incorporate an internal universal power supply and have a recessed male IEC connector for the AC power cord at the left-rear. A manual power ON-OFF switch is adjacent. A six-foot 115 VAC 60 Hz standard power cord is supplied with each unit shipped within the United States and Canada.

The auto-ranging power supply supports installation environments where the AC voltage is from 90 to 260 volts with a power input frequency between 47 and 63 Hz. The 16-port units will consume over 20 watts of power typically. When connecting the Ethernet cabling, there is no need to power down the unit. Individual cable segments can be connected or disconnected without concern for AC power-related problems or damage to the unit.

Power supply options are available to suit the 6K8-Series Switches to special

high-availability communications and/or heavy industrial-grade applications, including:

- * -48VDC, 24VDC and 125VDC with single DC input,
- * -48VDC, 24VDC and 125VDC with dual-source DC input,

See the Appendices B & C of this manual for more details. Use an RFQ for other variations.

3.5 Alarm Contacts for monitoring internal power, and Software Traps

The Alarm Contacts feature, standard on Magnum 6K8-Series's, provides two Form C Normally Closed (NC) contacts to which the user can attach two sets of status monitoring wires at the green terminal block. When this option is present, the terminal block for Alarm Contacts is part of the Power Input panel in the Magnum 6K8-'s case. The AC or DC power input connection is in the same panel. A manual On-Off Switch for power to the unit is not available on 6K8- units with the Alarm Contacts option, as these two features occupy the same space in the case.

The first NC Alarm Contact (top position) is a "Software Alarm", operated by user settings in the MNS-6K software. The user can disable the Software Alarm feature with a software configuration command if desired. When the Software Alarm is enabled, the Form C Normally Closed (NC) contact is held close during normal software operation. A user-defined software malfunction, such as an SNMP Trap or a Software Security violation or an S-Ring Fault, causes the contact to open and thus trigger an alarm in the user's monitoring system

The second (bottom position) NC Alarm Contact is held close when there is power on the main board inside of the 6K8-. This provides a "Hardware Alarm" because the NC contacts will open when internal power is lost, either from an external power down condition or by the failure of the power supply inside of the Magnum 6K8- Switch. Useful info. about Alarm contacts:

1. There is four terminal block (1,2,3,4) provided next to AC/DC power supply
2. The top two pins (1,2) are software operated
3. The bottom two pins (3,4) are hardware operated
4. By default it is NC (normally closed)
5. The software operation needs to be enabled and set to get the Alarm traps. For detail information about the Software Alarm and software control of SNMP alarm traps, please reference the Magnum MNS-6K Software User Manual. (Chapter 19th).

The Alarm Contact is on the front left area (next to the DC power source) of the Magnum 6K8-Series unit and is green in color as shown in the picture.



3.6 6K8-Series Port Module (6KPMV) Installation

Note: The modules used in the 6K8-Series vertical mount unit are similar to those used in 6K16V units. The modules have the letter "V" in the model numbers, to order the right module for this unit. In the Port Module materials below, all modules are

referred to as “6KPMV” for convenience in describing port module installation.

Magnum 6K8-Series Switches are normally received from the factory with all required 6KPMV modules installed. There may be situations where 6KPMV cards need to be added or replaced. In cases where additional 6KPMV cards are needed, the faceplate for an available front-mounted slot must be removed. The following procedure describes this operation. The pictorial view of the hardware assembly can be seen here-

http://www.garrettcom.com/Pictorial/6k8_pictorial.pdf

3.6.1 Preparation for Installing and Removing 6KPMVs from 6K8's

STOP!!!

Be sure the power cord is unplugged from the chassis before attempting to remove and/or replace any PM cards. Failure to do so may result in damage to the unit and will void the warranty.

Caution- Avoid Static Discharge: The port modules (like most electronic equipment) are sensitive to static discharge. Use proper ESD measures when handling port modules.

Step 1. Make sure the 6KPMV Card package has all necessary accessories and use the proper tool to install it properly. Each 6KPMV Card package, for field installation contains (Daughterboard (Bigger) and Granddaughter board (smaller), three 5/8 stand offs for Granddaughter board, 6 standoff for daughter Board, nine #4-40x3/8 Pan-Head screws along with Front panel face plate package.

NOTE: Every 6KPMV Card package comes with their matching Daughter and Granddaughter board. The copper 6KPMV card should not work properly if mixed with other Fiber combo 6KPMV card packages. Always install the PM module separately one by one to avoid the mixing.

Do not change the Blue color DIP Switch setting ever! Leave it at factory default.

Step 2. Remove Chassis Cover

The Magnum 6K8-Series chassis consists of top cover and bottom chassis assembled together with the help of 12 Philips-head screws. There are 4 screws located on the top-side panel of the unit (2 each on both side), 8 for bottom chassis base of the unit. Remove these screws. Once these screws are removed, the top-cover is easily slide out to the front, off the chassis base, as shown in the picture above in Fig. 3.6.1a.

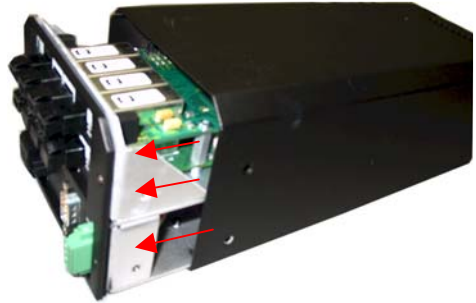

Figure 3.6.1a: Removing the Top panel from the Chassis base of the unit

Caution: Be careful not to disturb the power supply.

When the chassis top cover has been removed, the interior of the unit is exposed. Looking down into the Magnum 6K8-Series unit, notice that there are PM module installed and daughter module would be facing your eyes on the top installed on the main board with J5 and DSSV pins connected on the right. (See Figure 3.6.1b) below.

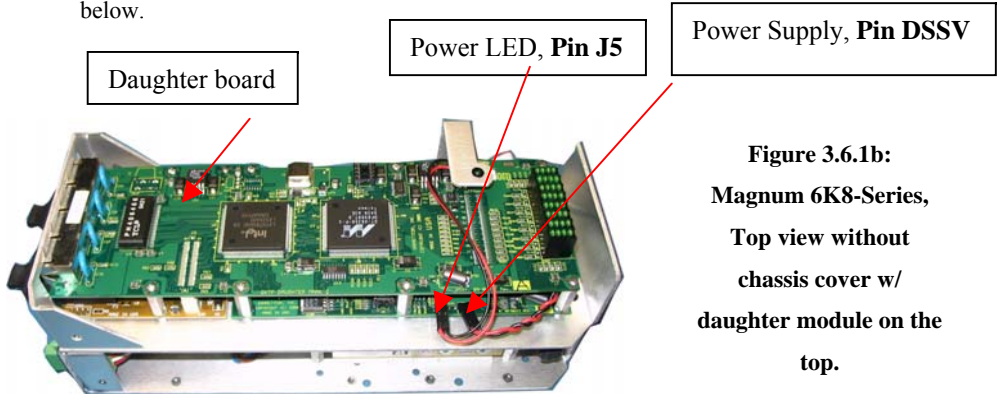

Figure 3.6.1b: Magnum 6K8-Series, Top view without chassis cover w/ daughter module on the top.

Note: Un-hooked the J5 and DSSV connected wires first as shown in Figure above with arrow mark.

Step 3. Remove front panel face plate retaining screws and screen plate

There are four retaining screws as shown with arrow mark in Fig 3.6.1c holding the face plate of the chassis.

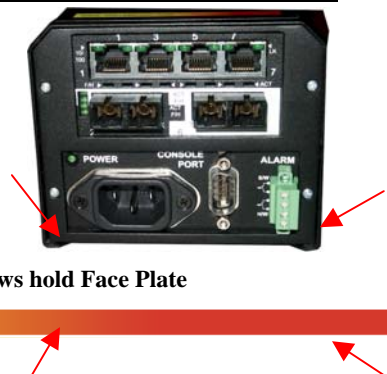

Figure 3.6.1c: Top View – 6KPM retaining screws hold Face Plate

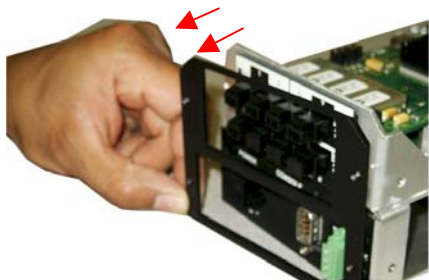

Figure 3.6.1d: Removing Face Plate

Carefully remove the PM screen plate using finger or small screw driver to come out easily as shown in Fig 3.6.1d on the right. Just be careful on the LEDs placed both side and hold the face plate tightly. There are no screws used on holding the screen face plate.

Once opened all the four retaining screws the front cover can be removed easily as shown in Fig 3.6.1d. on the left.

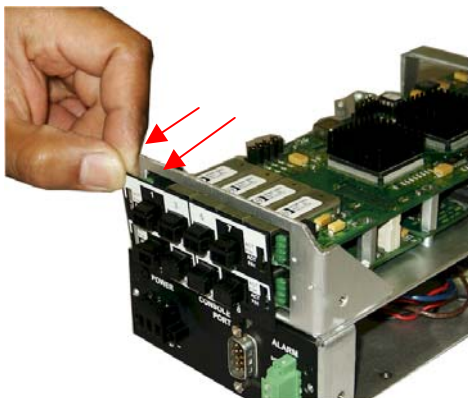

Figure 3.6.1d: Removing PM screen Plate

3.6.2 Installing 6KPM Cards in the Magnum 6K8-Series

Only one front-mounted 6KPMV Module may be installed in one Magnum 6K8-Series Field Switch unit. Follow these steps to install a 6KPMV.

Step 1. Remove top chassis cover. See procedure in Section 3.6.1 above.

Fig 3.6.2a A Magnum 6K8 unit with main board(motherboard) only



Step 2. Place Granddaughter board (as shown in fig. 3.6.2b) on the chassis built in stand off (female) provided at the front of the 6K8-Series Main Board. To place the Granddaughter board on the chassis, as shown in

Figure below 3.6.2c, screw down tightly with the three 5/16 stand-off (male) on the top of the Granddaughter board. The three 5/16 stand off has been used to place the daughter board on the top of the granddaughter board and a latch connector to hold it securely.

Fig 3.6.2b Granddaughter



Board shown separately

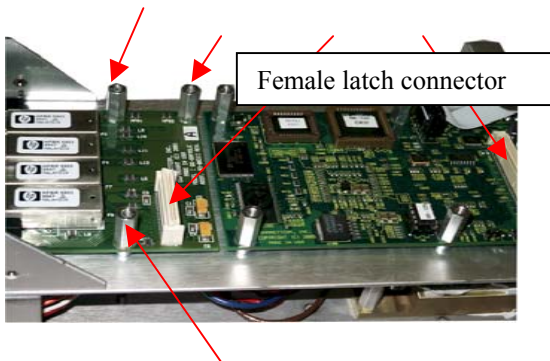

Female latch connector

Fig 3.6.2c Granddaughter Board placed in slot & secured with three 5/16 standoff's

Step 3. The figure here illustrates the basic layout of an individual PM card. Each 6KPM card fits into the space provided on the main board.



Fig. 3.6.2d Daughter Board, top view of

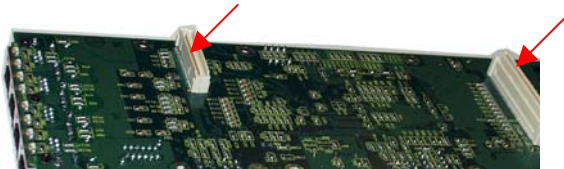

4 copper 10/100 ports

Fig 3.6.2e Daughter Board shown upside down with two male latch connectors

Step 4. Hold the daughter board with both hands at the end and insert the 6KPMV module inside the front face plate slot carefully. Then align it at the bottom of the daughter Granddaughter and main board. As

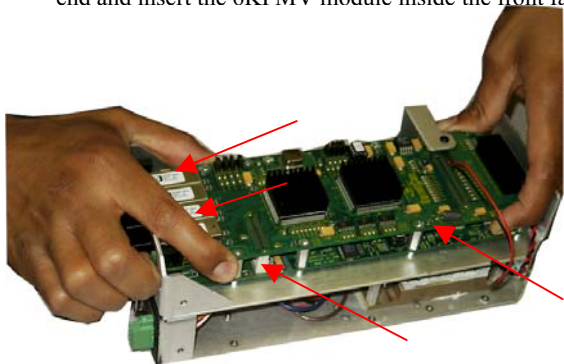
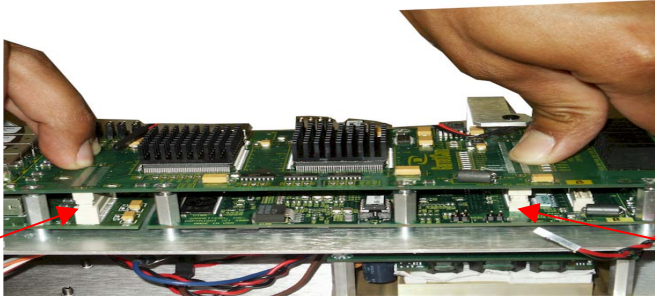

Fig. 3.6.2f Magnum 6KPM daughter board aligned with the bottom latch connector after inserted properly in front plate slot

Step 5. Once the latching connectors are aligned properly and the mounting holes are aligned with stand offs then press slowly and firmly with two fingers (as shown below in Fig. 3.6.2f) on the top of the latching connectors until the connectors latched up securely.



below in Fig. 3.6.2f) on the top of the latching connectors until the connectors latched up securely.

Figure 3.6.2f:
Securely latching up

6KPMV Cards into a Magnum 6K8-Series

Step 6. Now screw down the daughter board with 6 #440 screws, so that it holds the daughter board securely. The figure on the left shows the top view of successfully installed 6KPMV cards inside and the **Power Led(pin J5)** and **Power supply cable(pin DSSV)** connected to the board pins as shown in Fig 3.6.2g with arrows.



DSSV

J5

Fig. 3.6.2g Top View: 6KPM Module installed and insight for connecting two wires to the right pins

Step 7. Once the installation of granddaughter and daughter modules is done, the front panel screen plates of 6KPMV need to be placed on the face of the module securely and carefully. Now screw down properly the

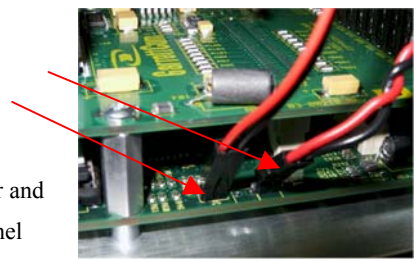

face plate with 4 screws to complete the installation process for port module.

The front panel screen plate does not need any screws to hold on port module, but need to place tightly and carefully while placing on LEDs.

- Step 8.** Once 6KPMV card have been installed (including faceplate and screen plate), the chassis cover should be replaced. Make sure the chassis top cover is aligned properly to the base before securely sliding the chassis base track inside the top

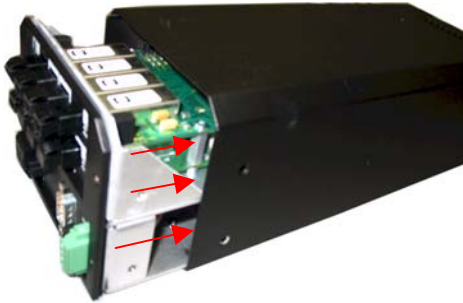

cover properly as shown in
Fig 3.6.2h

Fig. 3.6.2h
sliding in the top cover
onto the chassis base
track

3.6.3 Removing 6KPM Cards

To properly remove a 6KPM card from the 6K8-Series Industrial Field Switch, follow the 3 steps below.

- Step 1. Remove chassis cover** See procedures in Section 3.6.1 above.

Caution: Be sure the power cord is unplugged.

Step 2. Remove retaining screws placed on top of the 6KPMV and Face Plate

Each 6KPMV module is secured with nine retaining screws #440x3/8. These screws are used to secure a 6KPM card in position (see Figure 3.6.3a). Remove the 9 screws to take off the daughter module and thereafter three standoffs

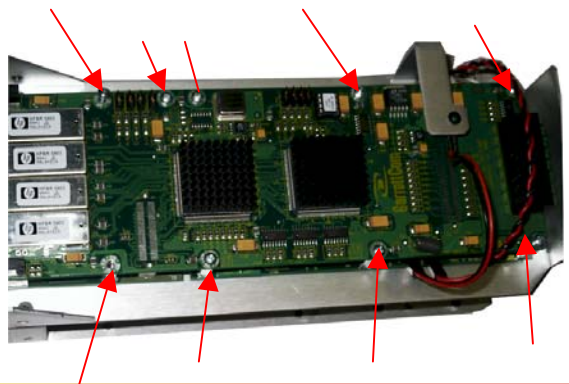

underneath holding the Granddaughter board with the chassis.

Figure 3.6.3a: 8

retaining screws shown by arrows

Step 3. Remove 6KPM Card

Carefully and gently pull out the daughter board from the latching connectors, using both hands, gripping the board near the latch-up connectors as shown in Fig. 3.6.3b

Figure 3.6.3b:

Removing a 6KPM Card

All the same procedures will apply for replacing any 6KPMV module from 6K8-Series managed switches. Follow the steps as described for installing a 6KPMV card discussed in step 3.7.1.

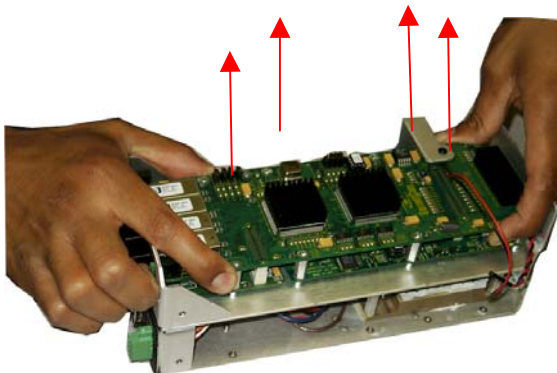

3.7 Connecting a Management Console Terminal to Magnum 6K8

Use a DB-9 “null modem” cable (use on any serial port) or “one DB-9 and one USB” (USB port on the laptop) null modem cable to connect the Magnum 6K8-Series Console Port (the RS-232 port on the 6K8-Series Switch) to your PC, so that your PC becomes the 6K8-Series’s Console Terminal. For Hyper terminal configuration to communicate with 6K-Series Switches, please follow the “Quick Step Guide” come along with the Switch.

http://www.garrettcom.com/techsupport/software/upgrade_mns6k.pdf

Note: A console cable (either of the two types) may be purchased as a separate item with the 6K8-Series unit. They are not “bundled” with the unit.

Console Serial.
(DB-9) Port

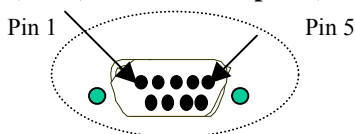

Fig 3.7 Enlarged view of Magnum 6K8-Series Console Port area

Note: For a detailed description of Managed Network Software (MNS-6K) and Magnum 6K8-Series Switch configuration for Network Management, please refer to

Magnum 6K8-Series Software Manual available on GarrettCom's FTP site. Please refer Section 2.2.9 of this manual for download information.

3.7.1 RS-232 (DB-9) Console Com port (Serial port) pin assignments.



DB-9 (Console port connector)

Pin	Signal	Description
1	CD	Carrier detect (not used)
2	RXD	Receive Data (input)
3	TXD	Transmit Data (output)
4	open	not used
5	GND	Signal Ground
6-9	open	not used

The above information enables a management station (a PC or Console terminal) to connect directly to the Switch Console using a straight-through serial cable.

4.0 OPERATION

This chapter describes the functions and operation of the Magnum 6K8-Series Switch.

4.1 Switching Functionality

A Magnum 6K8-Series provides switched connectivity at Ethernet wire-speed among all of its ports. The Magnum 6K8-Series supports 10/100Mbps for copper media and 10 or 100Mb separate traffic domains for fiber ports to maximize bandwidth utilization and network performance. All ports can communicate to all other ports in a Magnum 6K8-Series, but local traffic on a port will not consume any of the bandwidth on any other port.

Magnum 6K8-Series units are plug-and-play devices. There is no software configuring necessary to be done for basic operation at installation or for maintenance. The only hardware configuration settings are user options for an UP-LINK Switch (resides inside the unit) on the 6K8-RJ45. Optional Half / Full duplex mode and 10 or 100Mbps selection for the switched ports must be configured through MNS software per unit as per the requirement. The internal functions of both are described below.

Filtering and Forwarding

Each time a packet arrives on one of the switched ports, the decision is taken to either filter or to forward the packet. Packets whose source and destination addresses are on the same port segment will be filtered, constraining them to that one port and relieving the rest of the network from having to process them. A packet whose destination address is on another port segment will be forwarded to the appropriate port, and will not be sent to the other ports where it is not needed. Traffic needed for maintaining the uninterrupted operation of the network (such as occasional multi-cast packets) are forwarded to all ports.

The Magnum 6K8-Series Switches operate in the store-and-forward switching mode, which eliminates bad packets and enables peak performance to be achieved when there is heavy traffic on the network.

Address Learning

All Magnum 6K8-Series units have address table capacities of 4K node addresses suitable for use in larger networks. They are self-learning, so as nodes are added, removed or moved from one segment to another, the 6K8-Series Switch automatically keeps up with node locations.

An address-aging algorithm causes least-used addresses to fall out in favor of frequently-used addresses. To reset the address buffer, cycle power down-and-up.

4.2 Dual LEDs Status on TOP and Front of the 6K8-Series unit

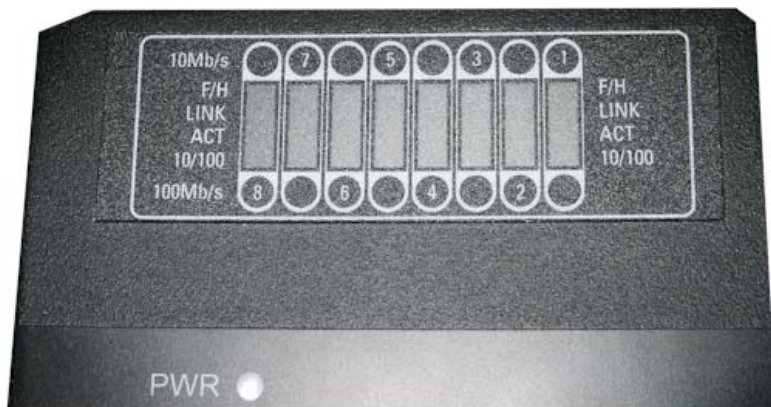

PWR/POWER : Power LED, ON when external power is applied to the unit.

LK/LINK : Steady ON, Link status for 10 Mbps and 100Mbps operation.

ACT : ON with port activity for 10 Mbps and 100Mbps operation.

F/H : Full / Half duplex LED, ON when the port is running full duplex, OFF for half duplex.

10/100 : Speed LED, ON when the speed is 100Mbps, OFF when the speed is 10 Mbps

4.3 Auto-Cross(MDIX) and Auto-negotiation, for RJ-45 ports

The RJ-45 ports independently support auto-cross (MDI or MDIX) in auto-negotiation mode and will work properly with all the other connected devices with RJ-45 port whether it supports Auto-negotiation or not (e.g 10Mb Hub, media converter) or fixed mode at 10Mb or 100Mb Half/Full Duplex(managed switch). No cross-over cable is required while using the 6K8's copper port to other devices. Operation is according to the IEEE 802.3u standard.

The Managed 6K8-Series Fast Ethernet copper ports, can be set for either fixed 100Mb speed or for 10/100 F/H N-way auto-negotiation per the IEEE802.3u standard. The selection is made via MNS software. The factory default setting is for auto-negotiation. At 10Mb or 100Mb-fixed speed, the user may select half- or full-duplex mode by MNS Software for each RJ-45 port separately. For detail information **See Section (10.1 at page no.52) of this manual to access the “6K-MNS(Rel 3) Software user guide”**

One frequently-used application for the Managed Magnum 6K8-Series Switch copper ports is to connect one of them using a fiber media converter to another Switch in the network backbone, or to some other remote 100Mb device. In this case, it is desirable to operate the fiber link at 100Mb speed, and at either half- or full duplex mode

depending on the capabilities of the remote device. Standard commercially available Fast Ethernet media converters mostly do not support auto-negotiation properly, and require that the switched port to which they are connected be at 100Mb fixed speed. Attachment to 10/100 auto-negotiation ports typically will not work properly. The 6K8-Series Switch's RJ-45 ports handle this situation by configuring the ports as per desire through MNS software port settings and can check the port status of each port after the change.

When Magnum 6K8-Series RJ-45 copper ports are set for auto-negotiation and are connected to another auto-negotiating device, there are 4 different speed and F/H modes possible depending on what the other device supports. These are: (1) 100Mb full-duplex, (2) 100Mb half-duplex, (3) 10 Mb full-duplex and (4) 10 Mb half-duplex.

The auto-negotiation logic will attempt to operate in descending order and will normally arrive at the highest order mode that both devices can support at that time. (Since auto-negotiation is potentially an externally controlled process, the original "highest order mode" result can change at any time depending on network changes that may occur). If the device at the other end is not an auto-negotiating device, the 6K8-Series's RJ-45 ports will try to detect its idle signal to determine 10 or 100 speed, and will default to half-duplex at that speed per the IEEE standard.

General information -

Auto-negotiation per-port for 802.3u-compliant switches occurs when:

- the devices at both ends of the cable are capable of operation at either 10 Mb or 100Mb speed and/or in full- or half-duplex mode, and can send/receive auto-negotiation pulses, and . . .
- the second of the two connected devices is powered up*, i.e., when LINK is established for a port, or
- the LINK is re-established on a port after being lost temporarily.

- **NOTE** – *Some NIC cards only auto-negotiate when the computer system that they are in is powered up. These are exceptions to the "negotiate at LINK – enabled" rule above, but may be occasionally encountered.*

When operating in 100Mb half-duplex mode, cable distances and hop-counts may be limited within that collision domain. The Path Delay Value (PDV) bit-times must account for all devices and cable lengths within that domain. For Magnum 6K8-Series Fast Ethernet switched ports operating at 100Mb half-duplex, the bit time delay is 50BT.

4.4 Flow-control, IEEE 802.3x Standard

Magnum 6K8-Series Switches incorporate a flow-control mechanism for Full-Duplex mode. The purpose of flow-control is to reduce the risk of data loss if a long burst of activity causes the switch to save frames until its buffer memory is full. This is most likely to occur when data is moving from a 100Mb port to a 10 Mb port and the 10Mb port is unable to keep up. It can also occur when multiple 100Mb ports are attempting to transmit to one 100Mb port, and in other protracted heavy traffic situations.

Magnum 6K8-Series Switches implement the 802.3x flow control (non-blocking) on Full-Duplex ports, which provides for a “PAUSE” packet to be transmitted to the sender when the packet buffer is nearly filled and there is danger of lost packets. The transmitting device is commanded to stop transmitting into the 6K8-Series Switch port for sufficient time to let the Switch reduce the buffer space used. When the available free-buffer queue increases, the Switch will send a “RESUME” packet to tell the transmitter to start sending the packets. Of course, the transmitting device must also support the 802.3x flow control standard in order to communicate properly during normal operation.

Note: When in Half-Duplex mode, the 6K8-Series Switch implements a back-pressure algorithm on 10/100 Mb ports for flow control. That is, the switch prevents frames from entering the device by forcing a collision indication on the half-duplex ports that are receiving. This temporary “collision” delay allows the available buffer space to improve as the switch catches up with the traffic flow. *The flow control option may (enable/disable) through setport command of MSN-6K software as per the requirement of network. By default the Flow control is disabled.*

4.5 Power Budget Calculations for Magnum 6K8-Series PM's with Fiber Media

Receiver Sensitivity and Transmitter Power are the parameters necessary to compute the power budget. To calculate the power budget of different fiber media installations using Magnum products, the following equations should be used:

$$\text{OPB (Optical Power Budget)} = P_T(\text{min}) - P_R(\text{min})$$

where P_T = Transmitter Output Power, and P_R = Receiver Sensitivity

$$\text{Worst case OPB} = \text{OPB} - 1\text{dB}(\text{for LED aging}) - 1\text{dB}(\text{for insertion loss})$$

$$\text{Worst case distance} = \{\text{Worst case OPB, in dB}\} / [\text{Cable Loss, in dB/Km}]$$

where the “Cable Loss” for 62.5/125 and 50/125 μm (Mm) is 2.8 dB/km,

and the “Cable Loss” for 100/140 (Multi-mode) is 3.3 dB/km,

and the “Cable Loss” for 9/125 (Single-mode) is 0.5 dB/km

and the “Cable Loss” for 9/125 (Single-mode) is 0.4 dB/km (LXSC25)

and the “Cable Loss” for 9/125 (Single-mode) is 0.25 dB/km (LXSC40)

and the “Cable Loss” for 9/125 (Single-mode) is 0.2 dB/km (LXSC70)

The following data has been collected from component manufacturer's (Agilent's and Lucent's) web sites and catalogs to provide guidance to network designers and installers.

Fiber Port Module	Speed, Std.	Mode	Std. km fdx (hdx)	Wave - length nm	Cable Size μ m	X'mittr Output P _T , dB	R'cvr Sens. P _R , dB	Worst OPB, dB	Worst* distance Km, fdx	typical OPB, dB	typical* distance Km, fdx
6KP4V-F10ST	10Mb FL	Multi-Mode	2 (2)	850	62.5/125 100/140 50/125	-15.0 -9.5 -19.5	-31 -31 -31	14 19.5 19.5	5 5.9 3.4	17 23.5 13.5	6 7 4.8
6KPV-MST, MSC	100Mb FX	Multi-mode	2 (0.4)	1300	62.5/125 50/125	-20 -23.5	-31 -31	9.0 5.5	3.0 2.0	14 12	5 4
6KPV-SSC	100Mb FX	Single-mode	18+ (0.4)	1300	9/125	-15	-31	14	28	17.5	35
6KPV-SSCL	100Mb FX	Single-mode	40 (0.4)	1300	9/125	-5	-34	29	58	32.5	65
6KPV-MTRJ	100Mb FX	Multi-mode	2 (0.4)	1300	62.5/125 50/125	-20 -23.5	-31 -31	9.0 5.5	3.0 2.0	15.8 12.2	5.5 4.0
6KPV-MLC	100Mb FX	Multi-mode	2 (0.4)	1300	62.5/125	-19	-31	12	4	16	5.7
6KPV-SLC	100Mb FX	Single-Mode	15+ (0.4)	1310	9/125	-15	-28	11	22	-	-
GBIC-SXSC	1000Mb	Multi-mode	0.55	850	62.5/125 50/125	-9.5	-17	5.5	2	12.5	4
GBIC-LXSC10	1000Mb	Single-mode	10	1300	9/125	-9.5	-20	8.5	17	10.5	21
GBIC-LXSC25	1000Mb	Single-mode	25	1550	9/125	-4.0	-21	15	37.5	17.5	43
GBIC-ZXSC40	1000Mb	Single-mode	40	1550	9/125	-4.0	-21	15	60	17.5	70
GBIC-ZXSC70	1000Mb	Single-mode	70	1550	9/125	-3.0	-23	18	90	20.5	102

* Note: The use of either multi-mode or single-mode fiber to operate at 100Mbps speed over long distances (i.e., in excess of approx. 400 meters) can be achieved **only** if the following factors are both applied:

- The 100Mb fiber segment must operate in full-duplex (FDX) mode, i.e. the full-duplex (factory default) setting for 100Mbps fiber ports must be used, and
- The worst-case OPB of the fiber link must be greater than the fiber cable's passive Attenuation.

(Attenuation = Cable loss + LED aging loss + Insertion loss + safety factor)

5.0 Introduction - Magnum 6K8 Industrial Field Switch Port Modules

This chapter describes each Port Module (PM), including appearance, functionality, and status displays.

5.1 Inspecting the Package and Product

This section applies only to PMs shipped as separate items, i.e., if 6K8 PMs not factory installed in a Magnum 6K8 PM slot.

Examine the shipping container for obvious damage prior to installing a 6K8 PM; notify the carrier of any damage you believe occurred during shipment or delivery. Inspect the contents of this package for any signs of damage and ensure that the items listed below are included.

This package should contain:

1 6K8-Series (6K8- series KPMVs)

Installation instructions, with illustrations

Remove the 6K8-Series PM(s) from the shipping container. Be sure to keep the shipping container should you need to ship any of the PMs separately at a later date. In the event there are items missing or damaged, contact your supplier. If you need to return the unit, use the original shipping container if possible. Refer to Chapter 5 for specific return procedures.

5.2 6KPMV Module Description

An important feature of the Magnum 6K8-Series is the use of Port Modules for flexible mixed-media connectivity to RJ-45 and fiber media. Since the Magnum 6K8-Series Switches have dual-speed capability for copper ports, the 2, 4, 6 or 8-port interfaces are designed to support all standard Ethernet media types at 10 or 100 or 1000Mbps speed. Each 6K8-Series PM provides a wide selection of connecting Ethernet media segments with all similar or combo connector type.

Note: The 6K8V Port modules are exactly similar in the functions, size and price, compared to 6K8- but addressed as e.g 6KP8V-RJ45 . For a correct list of 6K8 Port Module types, refer to Section 1.2

Each 6K8-Series PM is individually described in the following sections.

NOTE: *The 10/100 RJ-45 ports on all the modules, either all RJ-45 ports or used for COMBO module are featured with Auto-negotiation and Auto-Cross (MDIX).*

5.2.1 6KP6-RJMST, 4@10/100Mbps RJ-45 and 2@100Mb multi-mode FX-ST “twist lock” Combo Module

The Magnum 6KP6-RJMST is a combo 6 port module of four RJ-45’s at 10/100Mbps and two fiber optic ports at 100MB. The Combo module is equipped with dual-mode ST-type connectors and dual speed copper ports.

The ST-connector functions as a fiber optic transceiver to support 100BASE-FX network segments. When installed in a Magnum 6K8-Series Managed

Switch, the copper port supports the standard distance 100m on each port and the fiber

port supports fiber optic cable distances up the IEEE-standard 100Mbps distance limits, i.e., typically 2km at full-duplex and 412m at half-duplex.

Each port has an Activity (ACT) LED indicating packets being received, a Link (LK) LED that indicates proper connectivity with the remote device when lit, and FDX/HDX LED to indicate full-duplex mode when lit (or half-duplex when off). The 10/100 LED indicates the speed, if the LED is ON 100Mbps if it is OFF 10Mbps.

5.2.1a 6KP6-RJ10ST, 4@10/100Mbps RJ-45 and 2@10Mb multi-mode FX-ST “twist lock” Combo Module

The 6KP6-RJ10ST is a six port combo module that looks similar to the 100Mb combo module with the exception of 10Mb speed at the ST fiber module. The ST-connector functions as a fiber optic transceiver to support 10BASE-FX network segments. When installed in a Magnum 6K8-Series Managed Switch, the copper port supports the standard distance 100m on each port and the fiber port supports fiber optic cable distances up the IEEE-standard 10Mbps distance limits, i.e., typically 2km at full-duplex and half-duplex.

Each port has an Activity (ACT) LED indicating packets being received, a Link (LK) LED that indicates proper connectivity with the remote device when lit, and FDX/HDX LED to indicate full-duplex mode when lit (or half-duplex when off). The 10/100 LED indicates the speed, if the LED is ON, 100Mbps if it is OFF, 10Mbps.

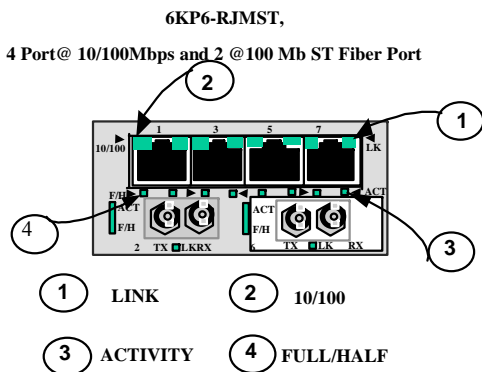

5.2.1b 6KP4-F10ST, 4@10Mb multi-mode FX-ST “twist lock” Module

The Magnum 6KP4-F10ST is a 10Mb multi-mode fiber module with 4 ST-Fiber ports. All four fiber ports are ST connectors and configured as 10Mb Half-duplex by default. The 10Mb ST-fiber ports allow the user to connect their legacy 10Mb network to the Magnum 6K8-Series switch. They also provide a convenient way for the half duplex

6KP4-RJ10MST,

4 Port@ 10Mb ST Fiber Port

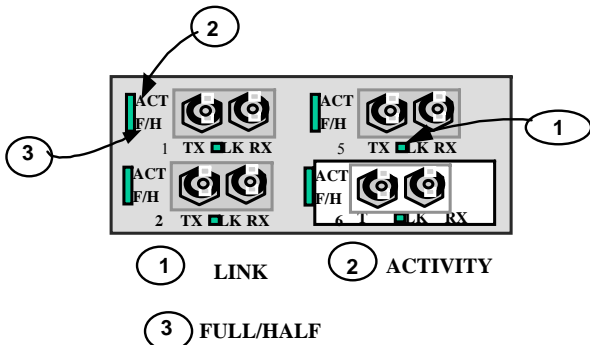

hub to connect to the switch through 10Mb fiber ports. It supports distances according to the 10Base-FL standard i.e, 2Km distance for multi-mode fiber. (Single-mode for 10Km distance may be available as a special order).

Each port has an Activity (ACT) LED indicating packets being received, a Link (LK) LED indicating proper connectivity with the remote device when lit, and FDX/HDX LED indicating full-duplex mode when lit (or half-duplex if off).

5.2.1c 6KP4-FLSTFX, 2@10Mb & 2@100Mb multi-mode FX-ST “twist lock” Module

The Magnum 6KP4-FLSTFX is a combo fiber module with two 10Mb + two 100Mb multi-mode fiber module and in combine 4 ST-Fiber ports. All four fiber ports are ST connectors and configured as 10Mb Half-duplex by default for 10Mb fiber and 100Mb Full duplex for the 100Mb fiber. The 10Mb ST-fiber ports allow the user to connect their legacy 10Mb network to the Magnum 6K8-Series switch. They also provide a convenient way for the

6KP4-RJ10MST,

4 Port@ 10Mb ST Fiber Port

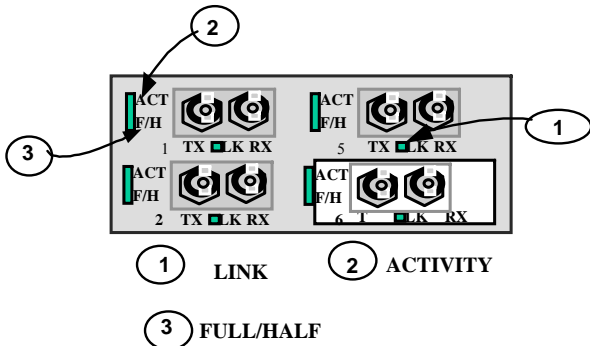

half duplex hub to connect to the switch through 10Mb fiber ports. Whereas the 100Mb ST fiber module, allow to connect the 100Mb demand of Switch devices. It supports distances according to the 10Base-FL standard i.e, 2Km distance for multi-mode fiber. (Single-mode for 10Km distance may be available as a special order).

Each port has an Activity (ACT) LED indicating packets being received, a Link (LK) LED indicating proper connectivity with the remote device when lit, and FDX/HDX LED indicating full-duplex mode when lit (or half-duplex if off).

5.2.2. 6KP6-RJMSC 4@10/100Mbps RJ-45 and 2@100Mb multi-mode FX-SC “snap-in” Fiber connector

The Magnum 6KP6-RJMSC is also a Combo 6 Port module equipped with 4 10/100Mb RJ-45 ports along with 2 multi-mode 100Mbps fiber optic transceivers all in one module. This is similar to the 6K6-RJMST. It has the same LEDs indicating port activity (ACT), Link (LK), and FDX / HDX and 10/100 operation, and the same face-plate lettering.

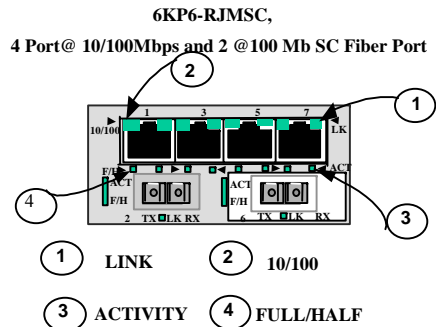

While the functionality of these two modules is essentially the same, the 6KP6-RJMSC is equipped with an SC-type "snap-in" connector instead of an ST-type.

5.2.3 6KP6-RJSSC 4@ 10/100Mbps RJ-45 Ports and 2@100Mbps single-mode FX-SC-type, “snap-in” connector

The Magnum 6KP6-RJSSC is also a Combo module equipped with 4 dual speed copper ports and 2 Single-mode SC-type connectors. It provides an advantage through combining copper and Fiber functions in one module of the 6K8-Series Switch supporting four Copper and two single-mode fiber

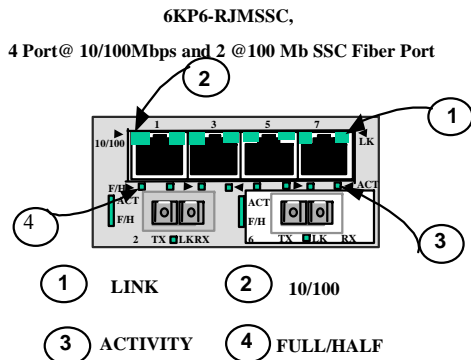

network segments.

The 6KP6-RJSSC, when installed in a Magnum 6K8-Series Switch operates on copper at the 100m distance. The Fiber is single-mode and cable lengths can be as much as 25+ Km (see Power Budget, Section 4.5)

Each port has an Activity (ACT) LED indicating packets being received, a Link (LK) LED that indicates proper connectivity with the remote device when lit, and a FDX/HDX LED to indicate full-duplex mode when lit (or half-duplex when off). The 10/100 LED indicates 100Mbps speed when lit and at 10Mbps speed when off. To distinguish the single-mode 6 K6-RJSSC from the multi-mode 6K6-RJM5C, the label “Sgl. M.” is at the top of the faceplate of the 6K6-RJSSC.

5.2.4 6KP6-RJSSCL 4 @ 10/100 Mb copper port and 2@100Mbps single-mode FX-SC-type, “snap-in” connector

The Magnum 6KP6-RJSSC is also a Combo module equipped with 4 dual speed copper ports and 2 Single-mode (Long Reach) SC-type connectors. It provides a combination of copper and Fiber functions in one module to the 6K8-Series Switches, supporting four Copper and two single-mode (Long-Reach) fiber network segments.

The 6KP6-RJSSC, when installed in a Magnum 6K8-Series Switch has copper supporting the 100m distance and Fiber supporting single-mode fiber cable lengths of as much as 40+ Km (see Power Budget, Section 4.5)

Each port has an Activity (ACT) LED indicating packets being received, a Link (LK) LED indicating proper connectivity with the remote device when lit, and a FDX/HDX LED indicating full-duplex mode when lit (or half-duplex when off). The 10/100 LED indicates the speed for the copper port, which is 100Mbps when the LED is ON and 10 Mb, when the LED is OFF.

5.2.4a 6KP6-RJ10ST 4 @ 10/100 Mb copper port and 2@10Mbps multi-mode FL-ST-type, “twist-lock” connector

The Magnum 6KP6-RJ10ST is also a Combo module equipped with 4 dual speed copper ports and 2 multi-mode 10 Mb fiber ST-type connectors. It provides a combination of copper and Fiber functions in one module to the 6K8-Series Switches, supporting four Copper and two 10Mb of ST fiber network segments.

The 6KP6-RJ10ST, when installed in a Magnum 6K8-Series Switch has copper supporting the 100m distance and Fiber supporting multi-mode fiber cable allow to connect the legacy network of 10Mb requirement in the network. Each port has an

Activity (ACT) LED indicating packets being received, a Link (LK) LED indicating proper connectivity with the remote device when lit, and a FDX/HDX LED indicating full-duplex mode when lit (or half-duplex when off). The 10/100 LED indicates the speed for the copper port, which is 10Mbps when the LED is ON and 10 Mb when the LED is OFF.

5.2.5 6KP8-MTRJ, 8 @100Mb multi-mode FX , MTRJ Small-Form-factor

Magnum 6KP8-MTRJ is a multi-mode fiber optic 8-port module equipped with a small-form-factor MTRJ-type connector. It looks almost like an RJ-45 port, but it is black in color. The MTRJ's small size and ease of connection make it a good choice for 100Mbps "fiber-to-the-desktop" Ethernet connectivity. When installed in a Magnum 6K8-Series Switch, it supports fiber optic cable distances up to the IEEE-standard 100Mbps distance limits, i.e., typically 2km at full-duplex and 412m at half-duplex.

6KP8-MTRJ, "small-form-factor" 8 Port @ 100Mbps Multi-Mode Fiber port

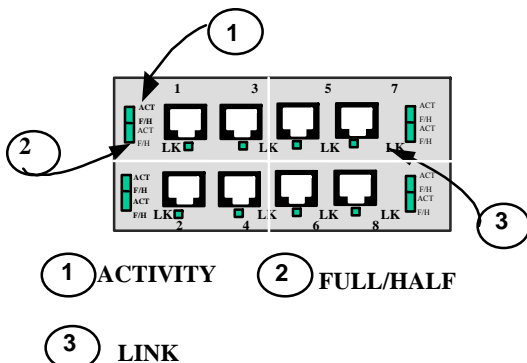

The functionality of this 100BASE-FX multi-mode 8 Port module is essentially the same as the ST and SC-types. It has the same LEDs per port indicating port activity (ACT), Link (LK), and FDX or HDX operation.

5.2.5a 6KP6-MT10ST, 4 @100Mb multi-mode FX , MTRJ Small-Form-Factor and 2@ 10Mb Multi-mode ST-Fiber port

The 6KP6-RJ10ST is a combo module with two different kinds of fiber flavor with two different speeds. The top four ports of MTRJ Small form factor fiber support at 100Mb full-duplex, whereas the bottom two ports multi-mode ST-Fiber support 10Mb half-duplex. This combo module provides more flexibility to the user to connect their legacy 10Mbfiber as well as 100Mb to the Magnum 6K8-Series Switch.

When installed in a Magnum 6K8-Series Switch, the 100Mb MTRJ connector supports fiber optic cable distances up to the IEEE-standard 100Mbps distance limits, i.e., typically 2km at full-duplex and 412m at half-duplex. The 10Mb Multi-mode ST-

Fiber connector supports the standard fiber optic distance limit of 2Km at Full and Half-duplex both.

The functionality of this 100BASE-FX multi-mode 4 port module is essentially the same as the ST and SC-types. It has the same LEDs per port indicating port activity (ACT), Link (LK), and FDX or HDX operation

5.2.6 6KP8-45MT, 4@ 10/100Mbps RJ-45 and 4@ 100Mb multi-mode FX , MTRJ Small-Form-Factor

The Magnum 6KP8-45MT

Module is a combo module with copper and fiber (Small Form Factor) MTRJ type ports. The small size of MTRJ connectors provides an advantage of placing more ports on one module. The 6KP8-45MT is equipped with 4 10/100 RJ-45 ports and 4 MTRJ fiber ports.

When installed in a Magnum 6K8-

Series Switch, it supports the standard distances as mentioned on 5.2.3. and the LEDs also act similarly.

5.2.7 6KP8-MLC, 8 ports @ 100Mbps multi-mode LC connector Small-Form Factor

8-Port@ 100Mbps multi-mode LC fiber port

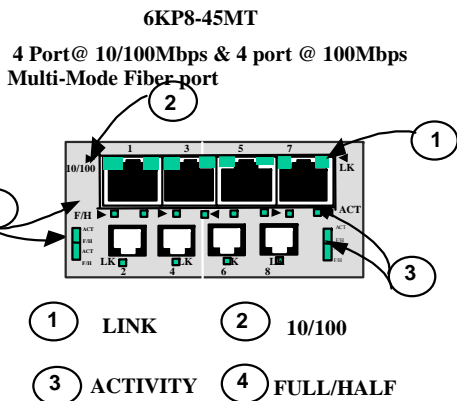
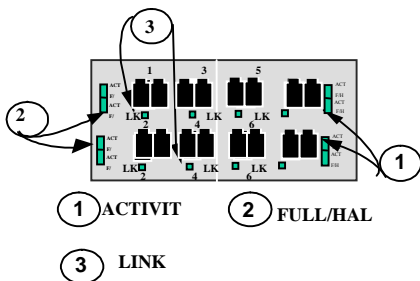

Magnum 6KP8-MLC is a eight-

port multi-mode fiber LC connector “small-form-factor” used primarily in 100Mbps fiber-to-the-desktop links.

When installed in a Magnum 6K8-Series Switch, it supports fiber optic cable distances up to the IEEE-standard 100Mbps distance limits, i.e., typically 2km at full-duplex and 412m at half-duplex.

The compact size of the LC Connector reduces the size of wiring panels in wiring closets while providing the advantage of “future-proof” fiber optic technology.

The cable end is a “plug-in” connector with both fiber strands terminated in one housing that cannot be improperly inserted. Each port has an Activity (ACT) LED

indicating packets being received, a Link (LK) LED indicating proper connectivity with the remote device when lit, and a FDX/HDX LED indicating full-duplex mode when lit (or half-duplex when off).

5.2.8 6KP8-45LC, Combo 4@ 100Mbps multi-mode -LC small-form factor and 4@ 10/100 Mbps RJ-45 Connector

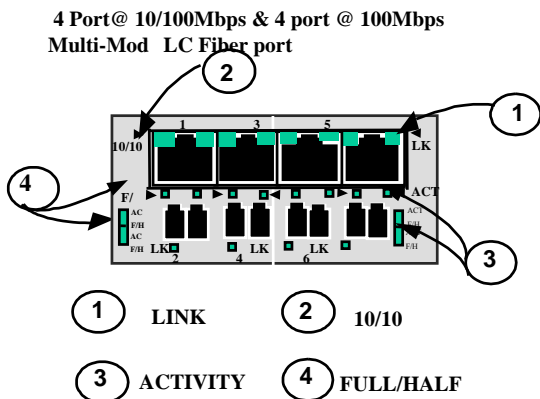

The Magnum 6KP8-

45LC Module is a combo module with a combination of copper and Fiber (Small Form Factor) LC type ports. The small size of LC connectors allows an advantage of having more ports on one module. The 6KP8-45LC is equipped with 4 10/100 RJ-45 ports and 4 LC (Small form factor) multi-mode fiber ports.

When installed in a Magnum 6K8-Series Switch, it supports the standard distances as per mentioned on 5.2.8. and the LEDs also acts similarly as mentioned above.

5.2.9 6KP8-RJ45 (Twisted Pair), 10/100Mb 8-Port

The 6KP8-RJ45 module supports Ethernet twisted pair segments of any standard length. It is equipped with an eight-port RJ-45 connector, and offers 10/100 full / half-duplex auto-negotiating capability on each port. The RJ-45 connector is shielded to minimize emissions and will allow both unshielded twisted pair (UTP) and shielded twisted pair (STP)

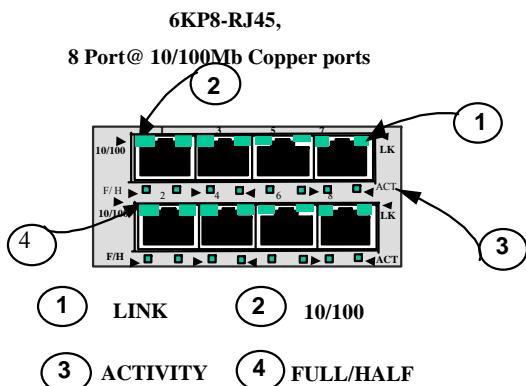

cable connections. The 6KP8-RJ45 module is equipped with a Media Dependent Auto-Crossover (MDI-X) switch, which controls all ports for cascaded connection. This

feature eliminates the need for a special twisted pair crossover cable when connecting to a hub or another switch.

Each port has an Activity (ACT) LED indicating packets being received, a Link (LK) LED that indicates proper connectivity with the remote device when lit, a FDX/HDX LED to indicate full-duplex mode when lit (or half-duplex when off), and a “10/100” LED indicating 100Mb when lit (or 10 Mbps when off).

Important Note: The 10/100 RJ-45 ports are supported with Auto-negotiation and Auto-crossover (MDIX), which allow the RJ-45 ports to automatically Link with any RJ-45 device and eliminate the use of cross-over cable.

5.2.10 6KP8-45-2MT, 6@ 10/100Mbps RJ-45 and 2@100Mb multi-mode FX , MTRJ Small-Form-Factor

The Magnum 6KP8-45-2MT eight port Module is a combo module with copper and fiber (Small Form Factor) MTRJ type ports. The small sizes of MTRJ connectors give an advantage of placing more fiber ports on one module. The 6KP8-45-2MT is equipped with six 10/100 RJ-45 ports and two 100Mb MTRJ fiber ports. When installed in a Magnum 6K8-Series Switch, it supports the standard distances as mentioned on 5.2.3. and the LEDs also act similarly.

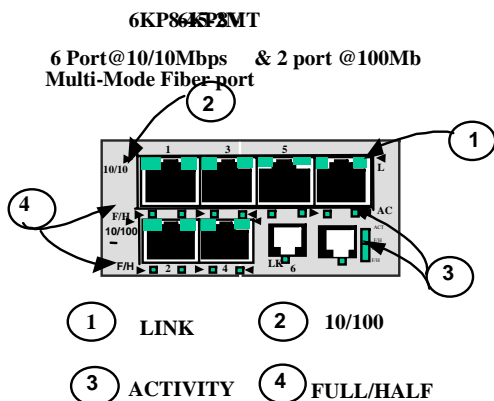

5.2.10a 6KP8-45-2LC, 6@ 10/100Mbps RJ-45 and 2@100Mb single-mode FX , LC Small-Form-Factor

The Magnum 6KP8-45SLC eight port Module is a combo module with copper and fiber (Small Form Factor) LC type fiber ports.

The small sizes of LC connectors provide an advantage of placing more ports on one module. The 6KP8-45-2SLC is equipped with 6 10/100 RJ-45 ports and 2 Single-mode fiber ports.

When installed in a Magnum 6K8-Series Switch, it supports the standard distances as mentioned on 5.2.4. and the LEDs also act similarly.

6KP8-45-2SLC
6 Port @ 10/100Mbps & 2 port @ 100Mbps
Single Mode Fiber port (LC)

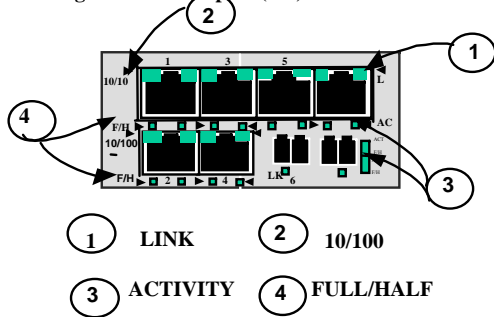

5.2.11 GBIC-SXSC Gigabit fiber(1000Mb), multi-mode SC Connector

The Magnum GBIC-SXSC is a multi-mode Gigabit fiber connector equipped with SC type connectors and can be easily snapped in and out. The Gigabit fiber ports are most popular as server-to-switch and switch-to-switch applications. It supports cable distances up to the IEEE 802.3z standard 1000Mbps distance limits, i.e., 550m at full duplex.

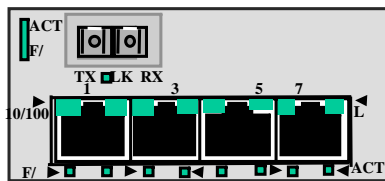

1 @ 1000Mb Fiber SC + 4 @ 10/ 100Mb

The GBIC transceiver has been offered in the modular slot with multiple options as per the user requirement. The two Giga port has been offered as GBPM-20TX (fiber or RJ-45), whereas the single Gigabit module comes in two different flavor of G+2 (100Mb fiber ports) or G+4(10/100 RJ-45 ports) as shown in the above figure.

The GBIC transceiver is fastened using snap-in clips. Insert the transceiver (take care to insert it the right way up, arrows on top) until it clicks in space. While removing the transceiver, press the clips on either side of the transceiver at the same time and pull the transceiver out.

Each port has an Activity (ACT) LED indicating packets being received and a Link (LK) LED indicating proper connectivity with the remote device when lit.

5.2.11a GBIC-LXSC Gigabit fiber (1000Mb), multi-mode SC Connector

The Magnum GBIC-LXSC is a single-mode Gigabit fiber connector equipped with SC type connectors and can be easily snapped in and out. The Gigabit fiber ports are most popular as server-to-switch and switch-to-switch applications. It supports cable distances up to the IEEE 802.3z standard 1000Mbps distance limits, i.e., 10,25, 40 or 70Km at full duplex, and depend upon the Gigabit modules used.

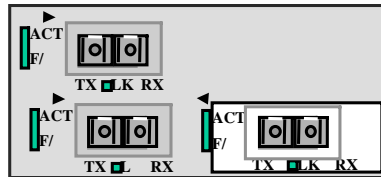

1 @ 1000Mb Fiber SC + 2 @ 100Mb SC

The two Giga port has been offered as GBPM-2OTX (fiber or RJ-45), whereas the single Gigabit module comes in flavor of G+4(10/100 RJ-45 ports) or G+2 (100Mb fiber ports) as shown below in the above figure.

Each port has an Activity (ACT) LED indicating packets being received and a link (LK) LED indicating proper connectivity with the remote device when lit.

6.0 TROUBLESHOOTING

All Magnum Ethernet products are designed to provide reliability and consistently high performance in all network environments. The installation of a Magnum 6K8-Series Switch is a straightforward procedure (see INSTALLATION, Section 2.6); the operation is also straightforward and is discussed in Section 4.

Should problems develop during installation or operation, this section is intended to help locate, identify and correct these types of problems. Please follow the suggestions listed below prior to contacting your supplier. However, if you are unsure of the procedures described in this section or if the Magnum 6K8-Series Switch is not performing as expected, do not attempt to repair the unit; instead contact your supplier for assistance or contact GarrettCom Customer Support.

6.1 Before Calling for Assistance

1. If difficulty is encountered when installing or operating the unit, refer back to the Installation Section of the applicable chapter of this manual. Also check to make sure that the various components of the network are interoperable.
2. Check the cables and connectors to ensure that they have been properly connected and the cables/wires have not been crimped or in some way impaired during installation. (About 90% of network downtime can be attributed to wiring and connector problems.)
3. Make sure that an AC power cord is properly attached to each Magnum 6K8-Series Switch unit. Be certain that each AC power cord is plugged into a functioning electrical outlet. Use the PWR LEDs to verify each unit is receiving power.
4. If the problem is isolated to a network device other than the Magnum 6K8-Series Switch product, it is recommended that the problem device be replaced with a known good device. Verify whether or not the problem is corrected. If not, go to Step 5 below. If the problem is corrected, the Magnum 6K8-Series Switch and its associated cables are functioning properly.
5. If the problem continues after completing Step 4 above, contact your supplier of the Magnum 6K8-Series Switch unit or if unknown, contact GarrettCom, Inc. by fax, phone or email (*support@garrettcom.com*) for assistance.

6.2 When Calling for Assistance

Please be prepared to provide the following information.

1. A complete description of the problem, including the following points:
 - a. The nature and duration of the problem;
 - b. Situations when the problem occurs;
 - c. The components involved in the problem;
 - d. Any particular application that, when used, appears to create the problem;
2. An accurate list of GarrettCom product model(s) involved, with serial number(s). Include the date(s) that you purchased the products from your supplier.
3. It is useful to include other network equipment models and related hardware, including personal computers, workstations, terminals and printers; plus, the various network media types being used.
4. A record of changes that have been made to your network configuration prior to occurrence of the problem. Any changes to system administration procedures should all be noted in this record.

6.3 Return Material Authorization (RMA) Procedure

All returns for repair must be accompanied by a Return Material Authorization (RMA) number. To obtain an RMA number, please use this URL - https://rma.garrettcom.com/rma/rma_request_noaccount.php to fill out the form. Please have the following information readily available:

Name and phone number of your contact person.
Name of your company / institution
Your shipping address
Product name
Serial Number (or Invoice Number)
Packing List Number (or Sales Order Number)
Date of installation
Failure symptoms, including a full description of the problem.

GarrettCom will carefully test and evaluate all returned products, will repair products that are under warranty at no charge, and will return the warranty-repaired units to the sender with shipping charges prepaid (see Warranty Information, Appendix A, for complete details). However, if the problem or condition causing the return cannot be duplicated by GarrettCom, the unit will be returned as:

No Problem Found.

GarrettCom reserves the right to charge for the testing of non-defective units under warranty. Testing and repair of product that is not under warranty will result in a customer (user) charge.

6.4 Shipping and Packaging Information

Should you need to ship the unit back to GarrettCom, please follow these instructions:

1. Package the unit carefully. It is recommended that you use the original container if available. Units should be wrapped in a "bubble-wrap" plastic sheet or bag for shipping protection. (You may retain all connectors and this Installation Guide.)

CAUTION: Do not pack the unit in Styrofoam "popcorn" type packing material. This material may cause electro-static shock damage to the unit.

2. Clearly mark the Return Material Authorization (RMA) number on the outside of the shipping container.
3. GarrettCom is not responsible for your return shipping charges.
4. Ship the package to:

**GarrettCom, Inc.
47823 Westinghouse Dr.
Fremont, CA 94539-7437
Attn.: Customer Service**

APPENDIX A: WARRANTY INFORMATION

GarrettCom, Inc. warrants its products to be free from defects in materials and workmanship for a period of three (3) years from the date of shipment by GarrettCom.

During this warranty period, GarrettCom will repair or, at its option, replace components in the products that prove to be defective at no charge other than shipping and handling, provided that the product is returned pre-paid to GarrettCom.

This warranty will not be effective if, in the opinion of GarrettCom, the product has been damaged by misuse, misapplication, or as a result of service or modification other than by GarrettCom.

GarrettCom reserves the right to make a charge for handling and inspecting any product returned for warranty repair which turns out not to be faulty.

Please complete the warranty card as this acts as a product registration, and mail it to GarrettCom within two weeks of your purchase.

APPENDIX B : Internal DC Power Supply Options

B1.0 SPECIFICATIONS FOR MAGNUM 6K8-SERIES SWITCHES, DC POWER

Magnum 6K8-Series models, for -48V and 24V DC & 125VDC Power input

Each Magnum Model 6K8-Series Managed Switch (DC option) requires a DC power source, for 24VDC, -48VDC and 125VDC option power input. The wide range of

power input qualifies this product for use in 24VDC, -48VDC as well as 125VDC environments. The 24VDC, -48VDC or 125VDC power input provides an Ethernet networking product utilizing a special type of power supply with a proven high-reliability record to fulfill the DC requirement.

DC Power Terminals: “+”, “-”, internally floating

GND: Terminal for “earth” or ground wire connection to the 6K8-Series chassis

Input Voltage: 18 to 36 VDC (24VDC)

Input current: 0.6Amps max.(for all RJ-45 ports)

Input current: 1.2Amps max.(for all Fiber ports)

Input Voltage: -36 to -70 VDC (-48VDC)

Input current: 0.4Amps max.(for all RJ-45 ports)

Input current: 0.7Amps max.(for all Fiber ports)

Input Voltage: 88 to 300 VDC (125VDC)

Input current: 0.1Amps max.(for all RJ-45 ports)

Input current: 0.125Amps max.(for all Fiber ports)

Power Consumption: 25 watts max., for fully loaded (fiber ports)

(24V, -48V, 125V)DC 8 watts typical for all (RJ-45 Ports)

B.2.0 -48VDC, 24VDC and 125VDC POWER, THEORY OF OPERATION

The -48VDC, 24VDC and

125VDC power options are designed using diodes inside on each DC power input line behind the two external power connection terminals, so that the power from an external source can only flow

into the switch. This allows the Switch to operate only whenever DC power is correctly applied to the two inputs. It protects the Switch from incorrect DC input connections. An incorrect polarity connection, for example, will neither affect the Switch, its internal power supply, nor will it blow the fuse in the internal power supply.

The manual power “On-Off” Switch (optional) is used for powering the unit on and off when it is placed into or taken out of service.

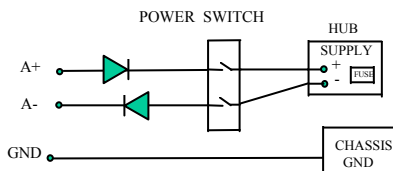

B.3.0 APPLICATIONS FOR DC POWERED ETHERNET SWITCHES

Magnum 6K8-Series Switches are easily installed in a variety of applications where -48VDC, 24, or 125VDC or 5VDC power is used as the primary power source. The DC power configuration capability

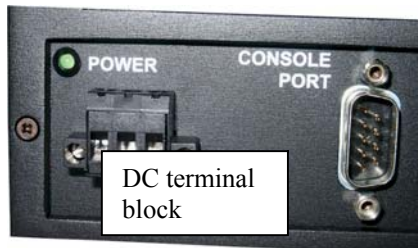

provides

an Ethernet networking solution utilizing a special power supply in switches with a proven track record.

Figure C5.0: -48VDC, wiring connections to the External Terminal Block on a Magnum 6K8 -48VDC

The -48VDC solution is particularly useful in the telecommunication industry, where it is common for facilities to operate on -48VDC power. Such companies include regular and wireless telephone service providers, Internet Service Providers (ISPs) and other communication companies. In addition, many high availability equipment services, such as broadcasters, publishers, newspaper operations, brokerage firms and other facilities often use a battery backup system to maintain operations in the event of a power failure. It is also frequently used for computer system backup, management and operations monitoring equipment.

The 24V and 125VDC options are particularly useful in the Industrial environment, where it is common for facilities to operate on 24VDC or 125VDC power. The 125VDC options are mainly used in power utilities, such as electrical substations, electrical generating plants, etc. The 24VDC applications are mainly in the Industrial environment, such as factory floor, HVAC equipment, military equipment, etc. The 5VDC options are mainly used for military or Industrial factory floor applications.

B4.0 6K8-SERIES, -48V, 24, 125 OR 5VDC INSTALLATION

This section describes the proper connection of the -48VDC leads (or 24VDC/125VDC/5VDC leads) to the DC power terminal block on the Magnum 6K8-Series Switch. The DC terminal block on the Magnum 6K8-Series Managed Switch is located on the left front of the unit and is equipped with three (3) screw-down lead posts. The power terminals are identified as positive (+) and negative (-), and they are floating inside the unit so that either may be grounded by the user if desired. The chassis is “earth” or ground (GND).

The connection procedure is straightforward. Simply insert the DC leads to the Switch’s power terminals, positive (+) and negative (-) screws. The use of Ground (GND) is optional; it connects to the Switch chassis. Ensure that each lead is securely tightened.

NOTE: Always use a voltmeter to measure the voltage of the incoming power supply and figure out the +ve potential lead or -ve potential lead. The more +ve potential lead will connect to the post labeled “+ve” and the rest to the “-ve”. The GND can be hooked up at the last.

When power is applied, the green PWR LED will illuminate.

Note: The GND should be hooked up first. The 6K8-Series unit has a floating ground,

so the user may elect to Ground either + or = terminal to suit the customer's use.

Before connecting hot lines to the Terminal Block of -48VDC, 24VDC or 125VDC, always use a digital voltmeter to measure the output voltage of the power supply and determine the lead which is more "+ve potential". The more "+ve" voltage lead from 48V or -48V supply must be connected to the post labeled "+".

B4.1 UL Requirements for DC-powered units

1. *Minimum 18AWG cable for connection to a Centralized DC power source.*
2. *Minimum 14AWG cable for connection to a earthing wiring.*
3. *Use only with Listed 10 A circuit breaker provided in building installation.*
4. *"Complies with FDA radiation performance standards, 21 CFR subchapter J." or equivalent.*
5. *Fastening torque of the lugs on the terminal block: 9 inch-pound max.*
6. *Centralized DC Power Source cable securement, use at least four cable ties to secure the cable to the rack at least 4 inches apart, with the first one located within 6 inches of the terminal block.*

B5.0 OPERATION

Operation of Magnum 6K8-Series Switches with the optional -48VDC, 24VDC and 125VDC power supply is identical to that of the standard AC-powered models.

Similarly to order the optional 24VDC or 125VDC industrial specific power supply factory installed, add a suffix of "24VDC" or "125VDC" after the product 's standard model #. Example: Magnum 6K8-Series- 24VDC, Magnum 6K8-Series-125VDC.

B7.0 TROUBLESHOOTING

Please refer to Section 6.0 for troubleshooting

APPENDIX C: Internal DC Dual-Source Power Option

C1.0 SPECIFICATIONS - FOR MAGNUM 6K8-SERIES FIBER SWITCH

Power Supply (Internal, -48VDC Dual-Source, model # Dual-Src-48V)

DC Power Connector: First Source: "A+", "A-", 2nd Source "B-", "B+"

GND: Terminal for "earth" or ground wire connection to the hub chassis

Input: Two separate sources, each at 36 - 70 VDC

Power Supply (Internal, 24VDC Dual-Source, model # Dual-Src-24V)

DC Power Connector: First Source: "A+", "A-", 2nd Source "B-", "B+"

GND: Terminal for "earth" or ground wire connection to the hub chassis

Input: Two separate sources, each at 18 - 36 VDC

Power Supply (Internal, 125VDC Dual-Source, model # Dual-Src-125V)

DC Power Connector: First Source: “A+”, “A-“, 2nd Source “B-“, “B+”

GND: Terminal for “earth” or ground wire connection to the hub chassis

Input: Two separate sources, each at 88 - 300 VDC

With the exception of the dual DC input power connections and the power supply, all specifications and configuration options for the Magnum 6K8-Series -48VDC, 24VDC and 125VDC models with this Dual-Source option are identical to those listed in the *Magnum 6K8-Series Fiber Switches Installation and User Guide*, including Appendix B “Internal DC Power Supply Option”

C2.0 MAGNUM 6K8-SERIES, with -48VDC, 24VDC and 125VDC Dual-Source option (OPTIONAL)

The 6K8-Series-Switch models with the internal -48VDC, 24VDC and 125VDC Dual-Source power supply are designed for installations where a battery plant is the power source, and where two separate power sources are utilized in order to increase operational uptime and to simplify maintenance.

The functionality of the Magnum 6K8-Series Switch -48VDC, 24VDC and 125VDC Dual-Source Option units is identical to the standard AC-powered models. Refer to the main sections of this *Installation and User Guide* for a detailed description of the Magnum 6K8-Series Switches.

C3.0 DUAL-SOURCE OPTION, THEORY OF OPERATION

The Dual-Source DC power option is designed using diodes inside of the chassis on each DC power input line. A diode is placed in each of the four input lines (behind the four external power connection terminals) so that power from an external source can only flow into the unit. This allows the unit to operate whenever DC power is correctly applied to either or both of the two inputs

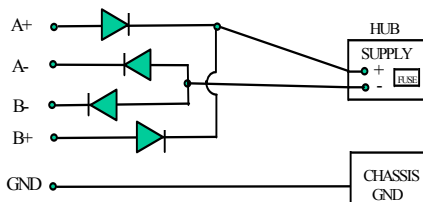
**C4.0 FEATURES AND BENEFITS OF THE DUAL-SOURCE DESIGN**

- The Switch unit can receive power from either input, “A” or “B”. The hub will normally draw its power from the DC source with the highest voltage at a given time.
- The Switch unit will not allow power to flow from a higher voltage input to a lower voltage input, i.e. the two DC power sources are not mixed together by the hub.
- When one correct DC input is present, the Switch will receive power if the other DC input is absent, or even if it is connected with reverse polarity or shorted or grounded.
- Reverse polarity connections, if they should accidentally occur on either input, will not damage the Switch or power supply internally (nor will it blow the fuse in the internal power supply)

because of the blocking action of the diodes. This is true even if one input connection is reversed while the Switch is operating from the other source.

- e) The Switch will not receive power (and will not work) when both inputs are simultaneously absent or are both incorrectly connected.

C5.0 INSTALLATION

This section describes the proper connection of the -48VDC, 24VDC and 125VDC dual source leads to the -48VDC, 24VDC & 125VDC power terminal block on the Magnum 6Ks Switch as shown in Fig.

The -48VDC terminal block on the Magnum 6K8-Series Switch, as shown in Fig C5.0 is located on the left front of the unit and is equipped with five (5) screw-down lead posts.



DC Terminal Block (Dual-Source)

The primary terminals are identified as positive (A+), negative (A-), and the secondary power terminals as negative (B-), positive(B+). The chassis “earth” or ground (GND) is a threaded post with a #6 nut. The Dual Source terminal block for the 24VDC and 125VDC are similar. **Figure C5.0: -48VDC-Dual-Src, wiring connections to the External Terminal Block on a Magnum 6K8 -48VDC**

Note: The GND should be hooked up first. The 6K8-Series unit has a floating ground, so the user may elect to Ground either + or = terminal to suit the customer’s use. Before connecting hot lines to the Terminal Block of -48VDC, 24VDC or 125VDC, always use a digital voltmeter to measure the output voltage of the power supply and determine the lead which is more “+ve potential”. The more “+ve” voltage lead from 48V or -48V supply must be connected to the post labeled “+”.

The connection procedure is straightforward. Simply connect the DC leads to the Switch’s power terminals, positive (+) and negative (-) screws. The use of Ground (GND) is optional; it connects to the Switch chassis. Ensure that each lead is securely tightened.

The 24VDC & 125VDC terminal block on Magnum 6K8-Series’s is similar to that described in the -48VDC information above.

C5.1 UL Requirements

The following must be adhered to in order to conform to UL requirements:

1. Minimum 18 AWG cable for connection to a Centralized DC power source.
2. Minimum 14 AWG cable for connection to earthing wiring.
3. Use only with Listed 10 A circuit breaker provided in building installation.
4. “Complies with FDA radiation performance standards, 21 CFR subchapter J.” or equivalent.
5. Fastening torque of the lugs on the terminal block: 9 inch pound max.

6. *Centralized DC Power Source cable securement, use at least four cable ties to secure the cable to the rack at least 4 inches apart with the first one located within 6 inches of the terminal block.*

C6.0 ORDERING INFORMATION (Optional)

To order the optional Dual-Source -48VDC power supply factory installed, order “Dual-Src48V” as a separate line item following the product model.

Example: **Magnum 6K8 -48VDC**

Dual-Src-48V for the regular DS model

Similarly, order the “Dual –source 24VDC” or “Dual-source 125VDC” as a separate line item following the product model.

Example: **Magnum 6K8 -24VDC**

C7.0 OPERATION

Operation of the Dual-Source Magnum 6Ks-48VDC, 24VDC and 125VDC Switch models are identical to that of the standard models.